



Gas



Liquid & Slurry



Solid & Powder



Steam & Water

SENTRY TUBE-IN-TUBE DTC-4 Heat Exchangers

SAMPLE CONDITIONING

Sentry® DTC-4 (dual tube coil) tube-in-tube heat exchangers are spirally wound, full counter flow heat exchangers well suited for a variety of applications where low flow rates of high temperature and/or high pressure fluids need cooling or heating.

MODELS

DTC-CUA/CUA-4-1-1

DTC-SSA/CUA-4-1-1

DTC-IN1/CUA-4-1-1

DTC-SSA/SSB-4-1-1

DTC-IN1/SSB-4-1-1

BENEFITS

The sturdy tube-within-a-tube concept uses heavy duty terminal fittings to provide for a plain tube end interface for the inner tube, and a compression connection for the outer tube. The plain end of the inner tube is easily adapted to a variety of connections including compression, threaded, socket weld, sanitary clamp and many more.

The tube-within-a-tube design also provides for high pressure/temperature capabilities on both sides of the heat exchanger, providing greater application flexibility.

The single continuous inner tube increases reliability and cleanliness and allows the unit to be completely drainable.

FEATURES

- Fully drainable inner and outer coil
- Spiral wound for maximum counter-flow efficiency
- Constant fluid velocity
- No dead spots or crevices
- Excellent for multi-phase/multi-component fluids and slurries
- Highly resistant to thermal and hydraulic shock
- Materials to meet any application: 300 grade stainless steel, copper, nickel alloys, titanium (inner tube only) or zirconium (inner tube only)

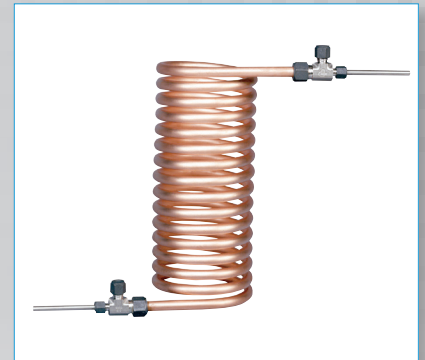

Sample. Monitor. Measure.



SENTRY

Any Application. Anywhere.

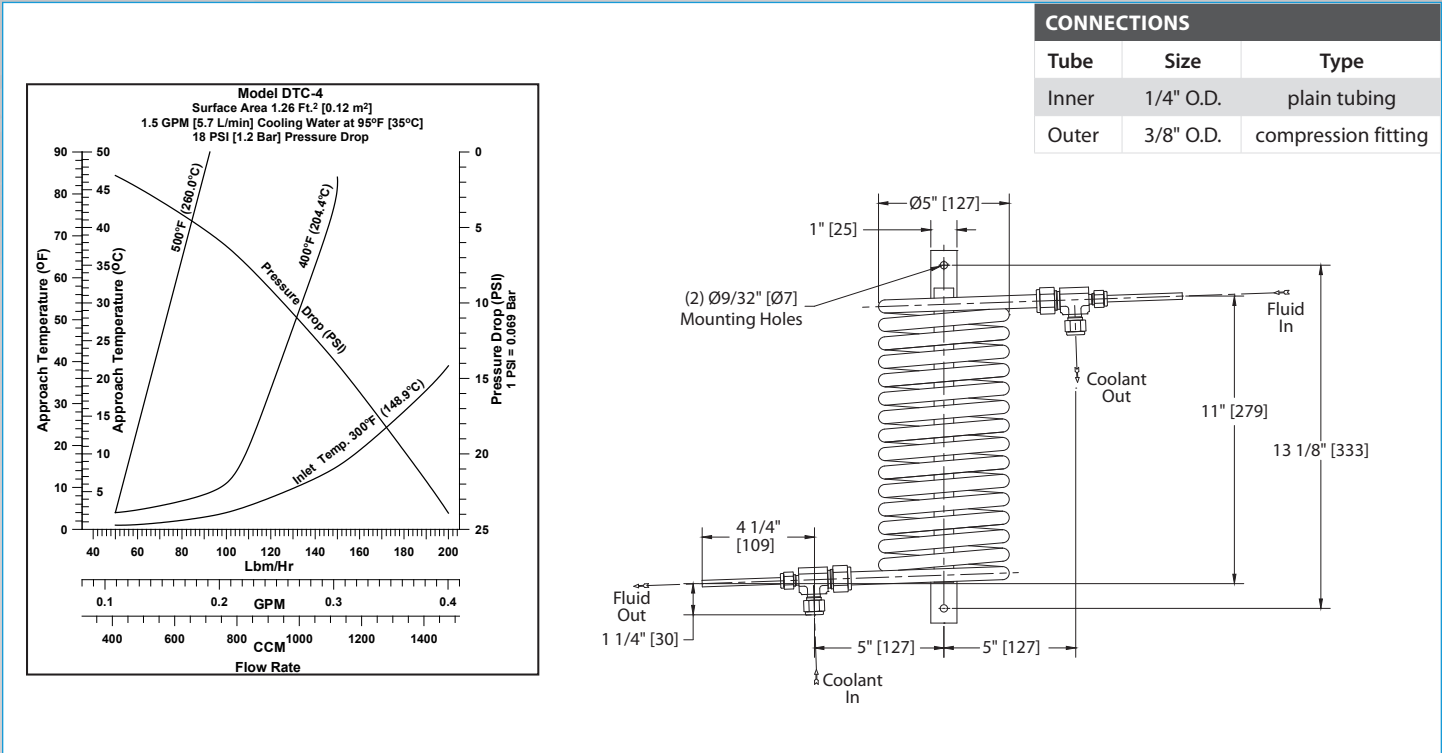

SPECIFICATIONS

models	inner tube design	outer tube design	inner tube material	outer tube material	heat transfer area	weight
DTC-CUA/CUA-4-1-1	2000 psi at 300°F (137 bar at 148°C)	700 psi at 300°F 48 bar at 148°C	1/4 in OD copper	1/2 in OD copper	1.26 ft² (0.12 m²)	12 lb (5.5 kg)
DTC-SSA/CUA-4-1-1	4900 psi at 1000°F (337 bar at 537°C)	700 psi at 300°F 48 bar at 148°C	1/4 in OD 316SS	1/2 in OD copper	1.26 ft² (0.12 m²)	12 lb (5.5 kg)
DTC-IN1/CUA-4-1-1	5450 psi at 1100°F (375 bar at 593°C)	700 psi at 300°F 48 bar at 148°C	1/4 in OD Inconel®	1/2 in OD copper	1.26 ft² (0.12 m²)	12 lb (5.5 kg)
DTC-SSA/SSB-4-1-1	4900 psi at 1000°F (337 bar at 537°C)	2300 psi at 1000°F 158 bar at 537°C	1/4 in OD 316SS	1/2 in OD 316SS	1.26 ft² (0.12 m²)	12 lb (5.5 kg)
DTC-IN1/SSB-4-1-1	5450 psi at 1100°F (375 bar at 593°C)	2300 psi @1000°F 158 bar @537°C	1/4 in OD Inconel®	1/2 in OD 316SS	1.26 ft² (0.12 m²)	12 lb (5.5 kg)

Performance data shows approach temperature (outer tube inlet + approach temp. = inner tube outlet temp) for three inner tube inlet temperatures and various flow rates. Data based on thermal properties of water. Cooling water 95°F (35°C) @1.5 GPM (5.7 L/min). Pressure drop <18 psi (1.2 bar). Consult company for other fluids flow, rates and pressure drops.

sentry-equip.com

966 Blue Ribbon Circle North, Oconomowoc, WI 53066 U.S.A. | +1-262-567-7256 | sales@sentry-equip.com



© 2017 Sentry Equipment Corp. All rights reserved. All product and company names are property of their respective owners. It is solely the responsibility of end users, through their own testing and analysis, to select products and materials suitable for their specific application requirements, ensure they are properly installed, safely applied and properly maintained, and to limit their use to their intended purpose. Improper selection, installation or use may result in personal injury or property damage.

S-SC&HE-SPS-00147-6 3-21

COMPANY WITH
QUALITY SYSTEM
CERTIFIED BY DNV GL
= ISO 9001 =