

Original Instructions

Installation, Operation & Maintenance Manual

Sentry Magnetic Trap MT-1 Magnetic Trap

S-SW-IOM-00441-2 05-18



COMPANY WITH
QUALITY SYSTEM
CERTIFIED BY DNV GL
= ISO 9001 =

 **SENTRY**

Table of Contents

Safety Information	3
General Safety Precautions	4
General Description	4
Installation.....	5
Operation.....	6
Maintenance.....	6
Technical Data	6
Standard Warranty	7
Customer Support.....	7



Do not install, maintain, or operate this equipment without reading, understanding, and following the appropriate Sentry Equipment Corp instructions. Otherwise, injury, damage, or both may result.

Copyright

© 2018 by Sentry Equipment Corp. All rights reserved. All product and company names are property of their respective owners. This document contains proprietary information. No part of this document may be photocopied or reproduced without the prior written consent of Sentry Equipment Corp.

Limit of Liability

Sentry Equipment Corp, its employees, agents, and the authors and contributors to this document specifically disclaim all liabilities and warranties, express or implied (including warranties of merchantability and fitness for a particular purpose), for the accuracy, currency, completeness, and/or reliability of the information contained herein and/or for the fitness for any particular use and/or for the performance of any material and/or equipment selected in whole or part with the user of/or in reliance upon information contained herein. Selection of materials and/or equipment is at the sole risk of the user of this publication.

Note

The information contained in this document is subject to change without notice.

Safety Information

Please read the entire manual before attempting to unpack, set up, or operate this product. Pay careful attention to all Warnings, Cautions, and Notes. Failure to do so could result in serious personal injury and/or equipment damage.

Use of Hazard Information

If multiple hazards exist, the signal word corresponding to the greatest hazard shall be used.

Definitions

DANGER

DANGER indicates a hazardous situation which, if not avoided, will result in death or serious injury.

WARNING

WARNING indicates a hazardous situation which, if not avoided, could result in death or serious injury.

CAUTION

CAUTION, used with the safety alert symbol, indicates a hazardous situation which, if not avoided, could result in minor or moderate injury.

NOTICE

NOTICE is used to address practices not related to personal injury.

NOTE

Information that requires special emphasis.

TIP

Alternate techniques or clarifying information.

SHALL: This word is understood to be mandatory.

SHOULD: This word is understood to be advisory.

General Safety Precautions

Product Selection, Installation, and Use

⚠ WARNING

Improper selection, installation, or use can cause personal injury or property damage. It is solely the responsibility of users, through their own analysis and testing, to select products suitable for their specific application requirements, ensure they are properly maintained, and limit their use to their intended purpose.

Follow proper local, state, and federal regulations for proper installation and operational requirements.

Always use caution and common sense when working with any chemical. Read the product label and Material Safety Data Sheets (MSDS) carefully and follow the instructions exactly.

Potential Equipment Hazards

⚠ WARNING

Hot surfaces! This equipment may have very hot surfaces. If an operator contacts a hot surface, injury may occur. Use protective clothing to prevent injury. If other equipment comes in contact with a hot surface, damage to the equipment may occur. Ensure the area around this equipment is kept clear to prevent this damage from occurring.

High pressures! This equipment may contain fluids at very high pressures. Prior to installing, removing, or maintaining this equipment, ensure that the equipment is isolated from all connecting piping, the equipment is depressurized, the contents have been drained, and the equipment is cool.

⚠ DANGER

Magnetic fields are present. Keep away from sensitive electronic devices and medical devices.

General Description

The Sentry® Magnetic Trap MT-1 is designed to collect fine magnetic particles such as magnetite in a fluid stream. The magnetic core is isolated from the fluid stream by a stainless steel sleeve. When supplied with the valve assembly (MT-1V), the trap is flushed with a 3-way ball valve on the discharge.



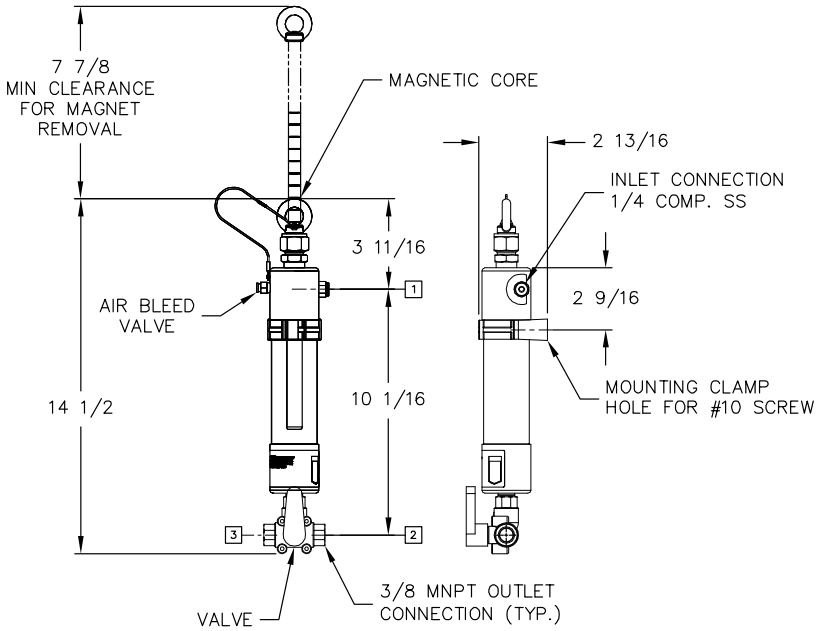

Installation

Refer to drawing (right) for proper location of the magnetic trap.

- The trap must be located downstream of the primary sample cooler.
- The trap must be located downstream of the pressure reducing valve to prevent over-pressurizing the trap.
- The magnetic trap needs to be properly supported.
- The magnetic trap should be mounted in a vertical orientation with enough space above it to allow lifting of the magnetic core.
- The magnetic core is on a tether to prevent removal. This is a safety measure to prevent personal injury: fingers or skin could become trapped between the strong magnet of the core and a ferrous surface.

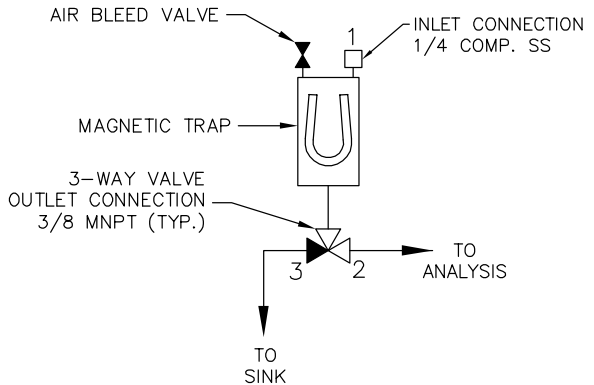

Operation

Under normal operation, with the valve handle in the Sample position, fluid flow enters the top of the trap and exits at the bottom of the trap. Optimal magnetite collection occurs below 1200 cc/min.

CAUTION

Prevent operator exposure to high pressure fluid.

NOTICE

It is the installer's responsibility to provide means to isolate the sample stream when flushing the magnetic trap and to prevent backflow from a high pressure source to a low pressure source.

Magnetic Trap RUN Mode

1. Insert magnetic core into trap.
2. Turn valve handle to SAMPLE position (vertical).
3. When starting up for first time, hold the air bleed valve open to bleed all air out of the trap.

Magnetic Trap FLUSH Mode

1. Place valve handle in FLUSH position (rotate counterclockwise).
2. Lift magnetic core out of trap.
3. Assuming the flush water is discharged into a sink, the fluid should turn clear as the magnetite flushes from the trap. This should occur within 15-30 seconds.
4. When the discharge runs clear, replace the magnetic core and return the valve handle to the Sample position (vertical).

Maintenance

The magnetic trap does not require maintenance; however, the valve in the MT-1V valve assembly may require periodic replacement.

Technical Data

Inlet Pressure Rating	100 psi (6.9 bar)
Max. Temperature Rating	140°F (60°C)
Materials	
Wetted Magnets	316 stainless steel, POM, polycarbonate, Buna-N, PP Neodymium
Maximum Flow	1200 cc/min

Standard Warranty

Sentry Equipment Corp (“Seller”) warrants products manufactured by it and supplied hereunder (“Products”) to be free from defects in workmanship and, to the extent materials are selected by Seller, to be free from defects in materials, in each case for a period as defined in the table below:

Product Line	Product Category	Warranty Period
Sentry®	1. Automatic Sampling 2. Corrosion Monitoring 3. Manual Sampling 4. Sample Conditioning 5. Sampling & Analysis Systems 6. Replacement Parts (without expiration dates)	Eighteen months from date of shipment or twelve months from startup, whichever occurs first
Waters Equipment	1. Sampling & Analysis Systems 2. Replacement Parts (without expiration dates)	Twelve months from date of shipment

To view the full warranty, go to www.sentry-equip.com/warranty.

Customer Support

With proven sampling expertise since 1924, Sentry products and services provide business operations the critical insights to optimize process control and product quality. We deliver true representative sampling and analysis techniques to customers around the globe, empowering them to accurately monitor and measure processes for improved production efficiency, output, and safety. Standing behind our commitments, we are determined to tackle any application, anywhere.

We know that running an efficient operation isn’t easy. It requires thorough, careful analysis of controlled, real-time data achieved through reliable, accurate, and repeatable process monitoring and measuring. By effectively conditioning, sampling, and measuring gas, liquid, slurry, powder, solids, steam, or water within their production environments, our customers obtain the critical insights they need to control and optimize their processes.

Yet, controlling your processes also means reliable customer support throughout the life cycle of your equipment.

- Customer Service—General information, warranty claims, order management.
- Installation Service—For systems that require specialized expertise upon installation.
- Technical Support—Troubleshooting, training, and technical manuals.
- Field Service & Retrofits—When a problem needs immediate attention.
- Replacements Parts & Consumables—Order your replacement parts and consumables.
- Sentry ProShield Services—Select from four ProShield Guardian service plans providing different levels of support to protect your large system investments with regularly scheduled maintenance.

To learn more, go to www.sentry-equip.com/support.

Serving customers
in more than 50 countries
across six continents worldwide.



Sample. Monitor. Measure.

SENTRY

Any Application. Anywhere.

[sentry-equip.com](https://www.sentry-equip.com)

966 Blue Ribbon Circle North, Oconomowoc, WI 53066 U.S.A. | +1-262-567-7256 | support@sentry-equip.com