

Installation, Operation & Maintenance Manual

Sentry PR-R1 Sampler Point Samplers

S-SP-IOM-00289-11 10-23

Keep for Future Reference

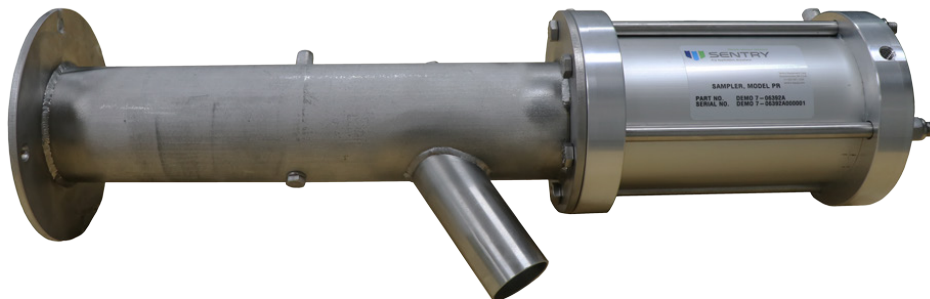



Do not install, maintain, or operate this equipment without reading, understanding, and following the appropriate Sentry Equipment Corp instructions. Otherwise, injury, damage, or both may result.

Copyright

© 2022 by Sentry Equipment Corp. All rights reserved. All product and company names are property of their respective owners. This document contains proprietary information. No part of this document may be photocopied or reproduced without the prior written consent of Sentry Equipment Corp.

Limit of Liability

Sentry Equipment Corp, its employees, agents, and the authors and contributors to this document specifically disclaim all liabilities and warranties, express or implied (including warranties of merchantability and fitness for a particular purpose), for the accuracy, currency, completeness, and/or reliability of the information contained herein and/or for the fitness for any particular use and/or for the performance of any material and/or equipment selected in whole or part with the user of/or in reliance upon information contained herein. Selection of materials and/or equipment is at the sole risk of the user of this publication.

Note

The information contained in this document is subject to change without notice.

Table of Contents

- Safety Information4
- General Safety Precautions5
- General Description6
- Installation6
- Operation.....8
 - Sample Bottle Assembly8
 - Sample Probe Speed.....8
- Maintenance9
 - Frequency.....9
 - Filter Regulator9
 - Seal Adjustment.....10
 - Seal Replacement.....10
- Troubleshooting14
 - Potential Problems14
 - Troubleshooting Sequence14
- Standard Warranty15
- Customer Support.....16

Safety Information

Please read the entire manual before attempting to unpack, set up, or operate this product. Pay careful attention to all Warnings, Cautions, and Notes. Failure to do so could result in serious personal injury and/or equipment damage.

Use of Hazard Information

If multiple hazards exist, the signal word corresponding to the greatest hazard shall be used.

Definitions

DANGER

DANGER indicates a hazardous situation which, if not avoided, will result in death or serious injury.

WARNING

WARNING indicates a hazardous situation which, if not avoided, could result in death or serious injury.

CAUTION

CAUTION, used with the safety alert symbol, indicates a hazardous situation which, if not avoided, could result in minor or moderate injury.

NOTICE

NOTICE is used to address practices not related to personal injury.

NOTE

Information that requires special emphasis.

TIP

Alternate techniques or clarifying information.

SHALL: This word is understood to be mandatory.

SHOULD: This word is understood to be advisory.

General Safety Precautions

Product Selection, Installation, and Use

WARNING

Improper selection, installation, or use can cause personal injury or property damage. It is solely the responsibility of users, through their own analysis and testing, to select products suitable for their specific application requirements, ensure they are properly maintained, and limit their use to their intended purpose.

Follow proper local, state, and federal regulations for proper installation, operation, transportation, storage, and decommissioning requirements.

Always use caution and common sense when working with any chemical. Read the product label and Safety Data Sheets (SDS) carefully and follow the instructions exactly.

Firefighting

NOTICE

When selecting the appropriate firefighting apparatus, the fire extinguisher shall be rated for electrical service and meet the requirements for the materials being sampled.

Potential Equipment Hazards

WARNING

Equipment rated TX. Equipment maximum surface temperature depends on operating conditions. Ensure maximum surface temperature shall stay below ignition temperature of dust or gas atmosphere where it is installed based on process conditions. Failure to comply could result in an explosion, causing serious injury or death to personnel and damage to equipment.

If the sampler is mounted directly to a non-electrically conductive surface, sampler shall be bonded to a grounding electrode. Failure to comply could result in sparking, which could lead to an explosion, causing harm to personnel and equipment.

If the sample container is removed from the sampler, do not insert any body part or other item into the sample discharge port. Crushing will occur.

NOTICE

To ensure proper sampler operation, be sure the sampler is installed in a pipe large enough for the sampler plunger to extend without impacting the pipe. Failure to comply will result in equipment damage and poor sample quality.

CAUTION

Sampler may require a two-person lift. Please refer to the General Arrangement drawing for weight and dimensional information.

General Description

The Sentry® PR automatic point sampler samples diluted and dense free-flowing materials such as granules, powders, flakes or pellets, as well as high viscosity or granulated liquids from gravity lines or positive or negative pressure systems. A sample is taken when a solenoid-controlled air cylinder moves a sample probe in and out of the product stream. The sample is then discharged to a collection container. When in the retracted position, air or other inert gases may be used to assist the displacement of the material in the sample tube.

Product characteristics are not changed by the sampler because no moving parts convey the product to the sample container. Sample size and frequency can be changed at the controller.

⚠ WARNING

Read these instructions completely before proceeding to assemble, install or operate this machine. This machine should be installed, operated and serviced by qualified individuals. All drive guards and doors must be secured in place when this machine is being operated. Follow proper local, state and federal regulations for proper installation and operational requirements.

TX	maximum temperature
T3	392°F (200°C)
T4	275°F (135°C)
T5	212°F (100°C)
T6	185°F (85°C)

ATEX Ratings:

Ex h IIB T5...T3 Gb
Ex h IIIC T99°C...T200°C Db
-20°C ≤ Ta ≤ +60°C

⇒ NOTE

The working pressure of the air cylinder is 100 psig with a max cycle rate of 6 cycles/min on a continuous duty cycle. Additionally, actuating gas needs to be a non-combustible neutral gas and the working temperature must be between -4°F to 149°F (-20°C to 65°C).

⇒ NOTE

Figures in this manual may differ from actual purchased equipment. Please refer to the drawings in the appendices of this document.

Installation

⚠ CAUTION

Sampler must be supported in two planes to prevent bending of the sample tube and to prevent personal and property damage.

NOTICE

Use industry code procedures to protect adapter from distortion. Major distortion cannot be corrected and will prevent installation of sampler.

1. Choose a location for the sampler. Product should be evenly dispersed in the material line. Make sure that the mounting location is six to eight feet beyond all elbows or line irregularities.
2. Mount the sampler to the line. Make sure the sample tube slot faces the flow of material so the sample can enter into the tube. The product discharge must face down.
3. If the sampler is premounted at the factory:
 - a. Remove a section of the conveying line equal to the length of pipe in which the sampler is mounted.
 - b. Insert the sample tube facing into the product flow.
 - c. Clamp or bolt sampler in position. See drawing included with this manual for additional details.
4. If any side of your chute or line is less than 5 in, use a transition section to enlarge the line at the point of installation. The shortest Sentry PR sample tube is 4 in.
5. If the sampler comes with mounting adapters:
 - a. If the line is horizontal, cut a $\text{Ø}2''$ [51] hole in the line to accommodate the sample tube.
 - b. If the line is vertical, cut a $\text{Ø}3''$ [76] hole in the line to accommodate the sampler tube.
 - c. Mount adapter wraps on the conveying line, making sure the hole in the adapter lines up with the hole in the conveying line. Then secure with the bolts.
 - d. Mount and fasten the sampler to mounting adapters with included hardware.
6. If the sampler is to be mounted to a chute that is 14 gauge or lighter, reinforce the chute with heavier gauge metal before bolting the sampler directly to the chute.
7. Mount the sample bottle assembly. It may be mounted in any convenient location below the sampler. Best results are obtained when, in the sampling position, the discharge of the sampler is in direct line with the intake of the sample bottle.
8. Connect a flexible hose from the sample discharge to the sample collection container. In certain applications, rigid metal tubing can be used following a short length of hose attached to the discharge.

3/8-16 TAPPED HOLE
FOR SUPPORT BRACKET
(BOTH SIDES)

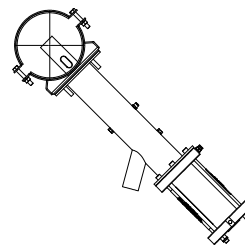
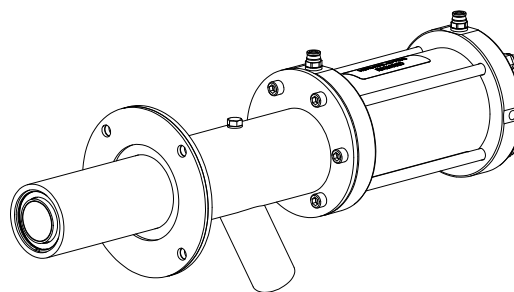

Horizontal Mount

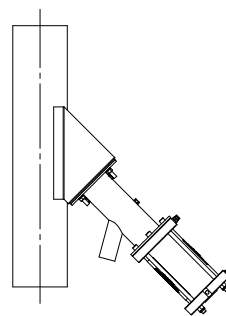

Vertical Mount

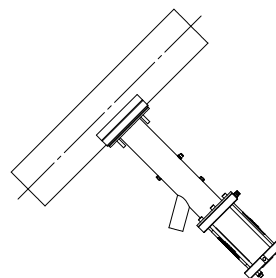

Angular Mount

9. Mount the filter-regulator and the solenoid-valve. The bowl should be in a vertical position as close as possible to the sampler. Air pressure of 60 to 80 psi normally is recommended (3.9 to 5.6 kilograms per square centimeter). The regulator and the restrictors are preset at the factory. Air usage is 8 cubic inches per inch of stroke. CFM depends on how often the sampler is actuated.

10. Connect the lines from the solenoid-valve marked C1 and C2 to the corresponding C1 and C2 marks on the air cylinders with 3/8 in OD poly tube (see figure, right).

11. Connect a clean air supply to the inlet of the filter-regulator. Oil and moisture filters should be used before the filter-regulator, if necessary. If an air lubricant is added to the system, it should be placed immediately after the filter-regulator. Air lines should not be so long that sharp bends or kinks develop in the lines. If an air purge is supplied, connect a purge gas source to the solenoid valve mounted on the sampler purge connection.

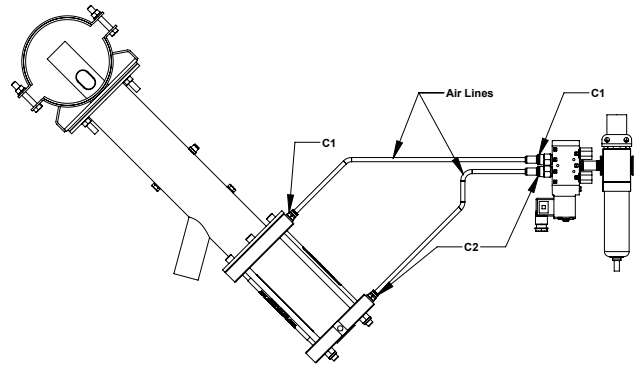

Operation

Sample Bottle Assembly

The valve on the sample bottle assembly is used to release pressure in the container. The valve may be opened a one quarter turn to allow pressure to bleed slowly between sampling cycles. The valve must be closed when sampling on a vacuum line.

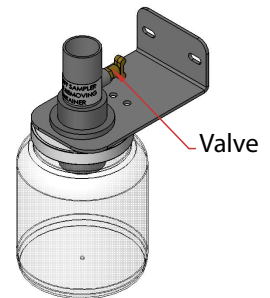

⚠ DANGER

Dangerous gas! The gases being emitted from the bottle vent may be hazardous and toxic upon exposures. The vent line should be directed to a charcoal canister, flare or other sub atmospheric region for collection and treatment of sample vapors.

⚠ WARNING

Open the valve on the sample bottle assembly to release the container pressure before removing the container. **DO NOT** open the valve by more than a quarter turn during sampling. Fine material may escape, biasing the sample and possibly causing personal injury.

Sample Probe Speed

The speed with which the sample probe extends and retracts can be increased or decreased by turning the flow controls on the four-way valve (see figure, below right). Each screw regulates the air exhausting from the cylinder. Turn the screw clockwise to decrease cylinder speed. When shipped from the factory, the advancing and retracting speeds are equal.

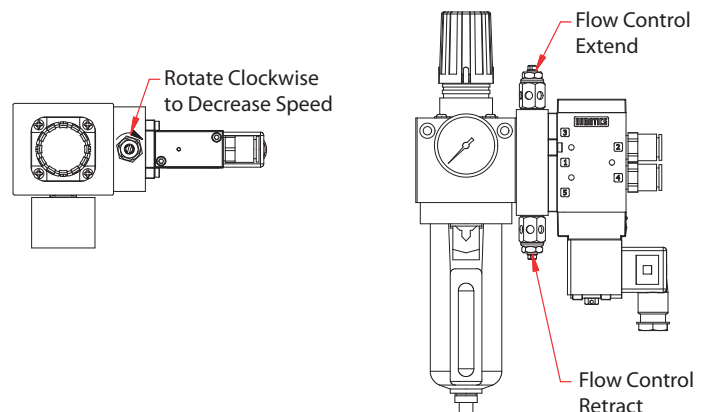

NOTE:

If you make an adjustment to the four-way valve, you may need to adjust the timers in the controller.

Maintenance

WARNING

Do not attempt to loosen or start disassembly of the sampler while the process line and pneumatic air cylinder are pressurized. All lines must be depressurized before any work can be done.

Frequency

Because the Sentry PR sampler can be used with a wide variety of products and installations, there are no definite guidelines on how often maintenance should be performed. Maintain the sampler very closely for the first three to four months from initial installation and document wear vs. usage. Using this information, determine a maintenance program that fits your specific environment.

Filter Regulator

1. Drain the filter/regulator at least once a week by turning the thumb screw on the bottom of the bowl (see figure, below). Draining frequency depends upon the quality of the air supply and may be required daily.

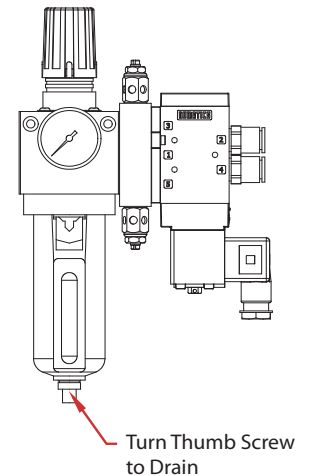

NOTE:

If an air lubricant is added to the system, it should be placed immediately after the filter regulator.

2. Excessive pressure drops or a visible coating on the filter element indicate cleaning of the filter regulator is necessary.
 - a. Shut off the air supply and remove the bowl.
 - b. Unscrew the lower gasket, allowing the filter element to fall out.
 - c. Wash the filter element with denatured alcohol.

NOTICE

Use an alkaline solution (soapy water) and not a solvent for cleaning the polycarbonate bowl.

- d. Clean the polycarbonate bowl with soapy water.
 - e. Reassemble the regulator and turn on the air supply.
3. Wash and blow out restrictors once a month or more frequently if necessary.
 4. Replaceable items for the filter-regulator are the filter, bowl and gauge (see drawing(s) in the Appendix of this manual for part numbers).

Seal Adjustment

Energized Seals

Standard samplers are supplied with maintenance-free energized seals. However, once the seals become worn they do need to be replaced (see "Seal Replacement" section in this manual).





⚠ CAUTION

Make sure that chevron seals are properly packed in order to prevent premature failure of the sampler. Tighten packing nut while the sample tube is being stroked out of the housing. Use caution to avoid injury.

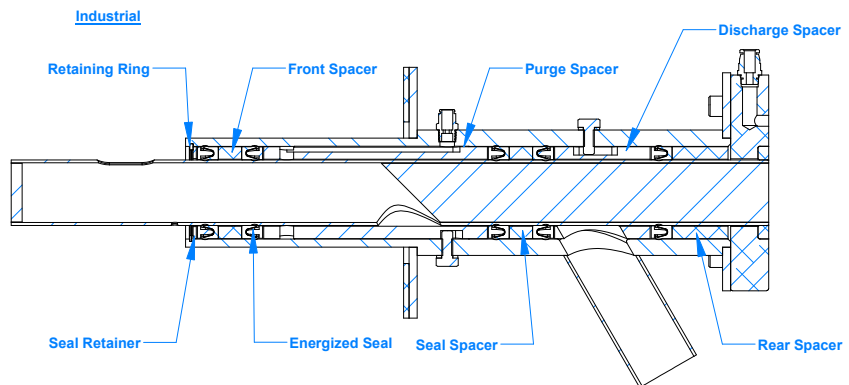
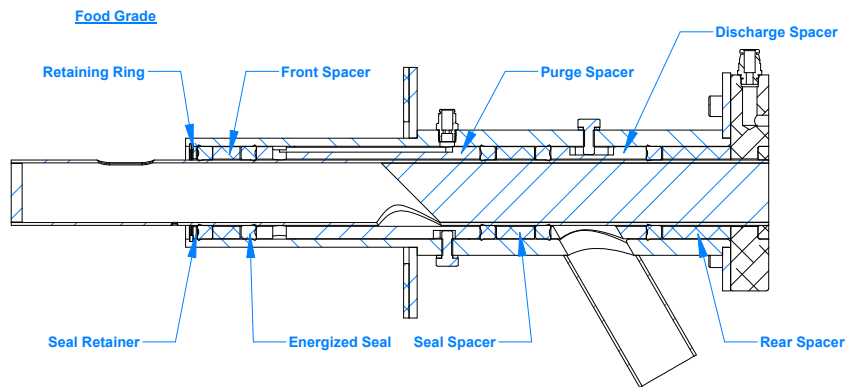
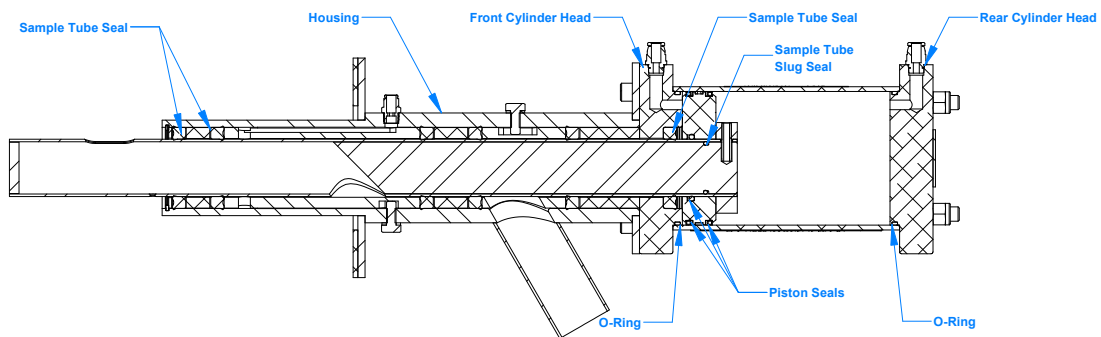
Housing Seal Replacement

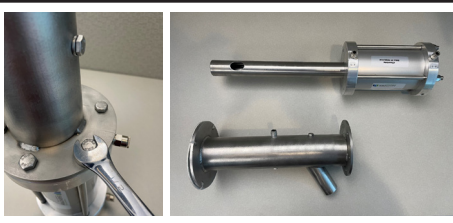
If the seals become worn, you must remove and replace them.

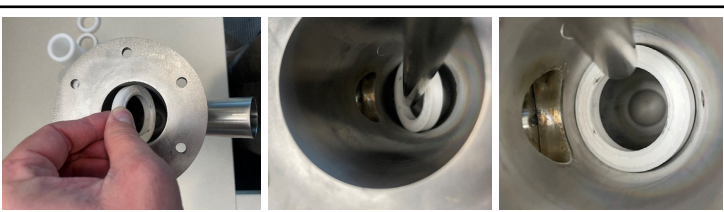
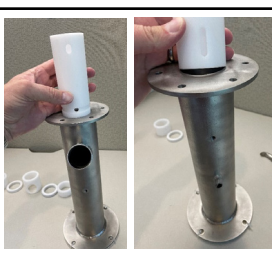

<p>1. Remove (6) bolts holding sampler housing to cylinder assembly.</p>	
<p>2. Remove (2) spacer alignment bolts from housing.</p>	
<p>3. Remove all spacers and seals from housing. <i>Note orientation and reference assembly drawing.</i></p>	
<p>4. Install seals and spacers according to assembly drawing. Slide the seals into the housing on their side as shown taking care to avoid the discharge port.</p>	
<p>5. Align the slots on the purge and discharge spacers with the alignment bolt holes and install the bolts.</p>	
<p>6. Reinstall (2) spacer alignment bolts.</p>	
<p>7. Complete seal and spacer installation.</p>	

Sample Tube and Air Cylinder Service

1. Remove (4) 5/16 lock nuts from cylinder tie rods.



2. Disassemble cylinder.



3. Replace the seal and O-ring in the front cylinder head.



4. If replacing the sample tube separate the piston from the sample tube.



5. Replace piston seals, wear band and inner O-ring on the piston. Care should be taken to ensure the seals seat fully into the grooves of the piston.

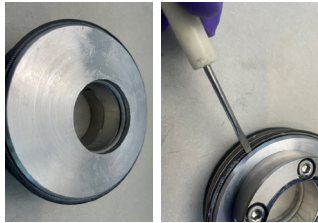

6. Reassemble piston to replacement sample tube.

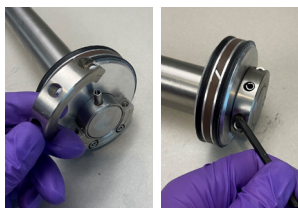

7. Carefully insert piston/tube assembly into cylinder tube. Slide the piston in sideways and then tip upright taking care not to damage the piston seals. The piston should be coated with a compatible air cylinder lubricant. Such as Krytox or Molycoat-33.



8. Reassemble the cylinder and tube assembly to the front cylinder head. Install the rear cylinder head and tighten the unlock nuts to 20 ft-lb.



9. Reinstall the cylinder and tube assembly into the housing assembly and tighten the 5/16 bolts to 20 ft-lb.



➔ **NOTE:**

Glass-filled Teflon seals will be slightly harder to slip the probe through, but once they are in, the probe will move freely.

NOTICE

Do not use solvents. A heavily scored cylinder should be replaced.

Troubleshooting

The following information is a synopsis of the problems you may encounter prior to troubleshooting your equipment. Divide the unit into three sections and try solving the problem before you continue on.

Potential Problems

Electrical

- Controller
- Solenoid
- Connections
- Motor (if applicable)
- Circuit breaker

Pneumatic

- Air pressure
- Four-way valves
- Filter-regulator
- Air cylinder
- Restrictors
- Air lines

Mechanical

- Alignment (binding of tube)
- Motor coupler (if applicable)
- Broken or worn teeth on gears (if applicable)
- Packing
- Loose set screws (if applicable)

⚠ WARNING

Disconnect main power to controller before attempting any adjustments or disassembly.

Sampler must not be disassembled or removed from line until line is free of product, is at atmospheric pressure, all components are at safe temperature, and all services have been shut off.

Troubleshooting Sequence

1. Controller
2. Solenoid
3. Tubing kinks
4. Air pressure
5. Restrictors
6. Air cylinder
7. Packing
8. Alignment

Electrical

1. See controller manual.

Pneumatic

- 2., 3., 4., 5. Check air lines for kinks, breaks, etc. Air pressure to the filter/regulator should be 60-80 psi. If higher air pressure is required to activate the cylinder, then it is possible that the probe is bound or the four-way valve needs cleaning. Look at the air restrictors and make sure they are open and not clogged.

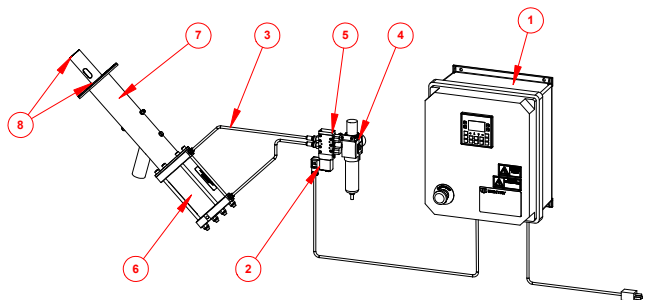

- If the probe slows up or stops when entering or retracting from the material line, the air cylinder seals may need replacing. If the main seal is worn, you may be able to hear air escaping around it.

Mechanical

- If the probe still does not function properly, check the seals for excessive wear or improper fit. If they need adjustment, see the Seal Adjustment section in this manual.
- If the sampler properly runs mechanically, but still does not function correctly, then remove it from the line. Check for obstructions in the tube. Reassemble and check for operation. If any other problems arise, please contact Sentry Equipment.

Standard Warranty

Sentry Equipment Corp (“Seller”) warrants products manufactured by it and supplied hereunder (“Products”) to be free from defects in workmanship and, to the extent materials are selected by Seller, to be free from defects in materials, in each case for a period as defined in the table below:

Product Line	Product Category	Warranty Period
Sentry®	1. Automatic Sampling 2. Corrosion Monitoring 3. Manual Sampling 4. Sample Conditioning 5. Sampling & Analysis Systems 6. Replacement Parts (without expiration dates)	Eighteen months from date of shipment or twelve months from startup, whichever occurs first
Waters Equipment	1. Sampling & Analysis Systems 2. Replacement Parts (without expiration dates)	Twelve months from date of shipment

To view the full warranty, go to www.sentry-equip.com/warranty.

Customer Support

With proven sampling expertise since 1924, Sentry products and services provide business operations the critical insights to optimize process control and product quality. We deliver true representative sampling and analysis techniques to customers around the globe, empowering them to accurately monitor and measure processes for improved production efficiency, output, and safety. Standing behind our commitments, we are determined to tackle any application, anywhere.

We know that running an efficient operation isn't easy. It requires thorough, careful analysis of controlled, real-time data achieved through reliable, accurate, and repeatable process monitoring, and measuring. By effectively conditioning, sampling, and measuring gas, liquid, slurry, powder, solids, steam, or water within their production environments, our customers obtain the critical insights they need to control and optimize their processes.

Yet, controlling your processes also means reliable customer support throughout the life cycle of your equipment.

- Customer Service—General information, warranty claims, order management.
- Installation Service—For systems that require specialized expertise upon installation.
- Technical Support—Troubleshooting, training, and technical manuals.
- Field Service & Retrofits—When a problem needs immediate attention.
- Replacements Parts & Consumables—Order your replacement parts and consumables.
- Sentry ProShield Services—Select from four ProShield Guardian service plans providing different levels of support to protect your large system investments with regularly scheduled maintenance.

To learn more, go to www.sentry-equip.com/support.

This page is intentionally left blank.

This page is intentionally left blank.

This page is intentionally left blank.

Serving customers
in more than 50 countries
across six continents worldwide.



Sample. Monitor. Measure.

SENTRY

Any Application. Anywhere.

sentry-equip.com

966 Blue Ribbon Circle North, Oconomowoc, WI 53066 U.S.A. | +1-262-567-7256 | support@sentry-equip.com