



Gas



Liquid & Slurry



Solid & Powder



Steam & Water

SENTRY B1 SAMPLER

Point Samplers

AUTOMATIC SAMPLING

The Sentry® B1 automatic point sampler automates sampling of dry free-flowing or non-free-flowing materials such as granules, powders, flakes and pellets from gravity lines, vertical chutes, sloping chutes and hoppers. A point sampler captures samples from a point in a process stream and often is used when the material is homogenous.

To obtain a sample, the Sentry B1 sampler first cleans out the sample tube by running the auger in reverse. After purging, the auger is run in the discharge direction and the sample moves through the assembly to the discharge port. The product sampled is discharged through a flexible hose to a collection point. Sample volume can be changed at the sampler controller. The sample probe is always in the product stream.

MODELS

B1

BENEFITS

With representative sampling, characteristics of each sample match that of the entire lot or batch – so samples are repeatable, leading to accurate sample analysis data. Automatic sampling ensures a sample can be easily and safely obtained with no need for direct human interface or interference. This ensures sample integrity as well as operator safety.

FEATURES

- Customized to meet various application needs
- Close tolerance between the auger and tube assures self-cleaning to help prevent cross-contamination
- Wetted components are 300 series stainless steel
- White silicone seal
- Total disassembly to ensure complete clean-up
- Auger reverses for clean-out of settled material in aperture opening
- Insertion lengths from 4 to 10 inches (102 to 254 mm)
- Available in a model conformant to 3-A Sanitary Standards through third-party verification
- CE and ATEX compliant models available
- Available with pneumatic or electric actuation for flexibility
- Includes air filter, regulator and gauge where applicable
- Release coating to ensure a non-stick surface
- QPQ hardening of contact surfaces to protect against wear and abrasion
- DC or explosion-proof motor
- Mounting adapters for round, square or other shaped chutes or pipes



Conforms to 3-A Sanitary Standards through Third-Party Verification (TPV)



Sample. Monitor. Measure.

SENTRY

Any Application. Anywhere.

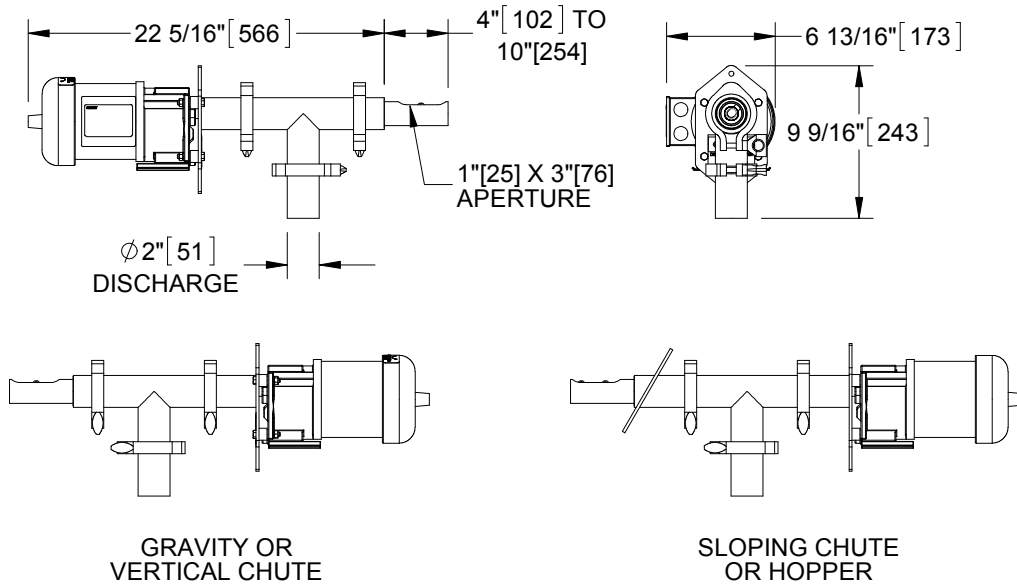

SPECIFICATIONS

materials	300 series stainless steel, white silicone, acetal
particle size	10 µm to 1/4 in (6 mm)
motor	1/6 HP gearmotor, 60 RPM, 115/230 V, 1 ph, 60 Hz; 110/220 V, 1 ph, 50 Hz TEFC
electrical requirements	115/230V, 1 ph, 60 Hz or 110/220 V, 1 ph, 50 Hz
temperature rating	-30 to 180°F (-34 to 82°C)
suggested connection to sample discharge	rigid metal or flexible tubing to a collection container or indexing cabinet
recommended sampler location	gravity chutes and hoppers
quantity of sample	24 cc per revolution max.
collection containers	PET jar, 304 stainless steel jar, bag
pressure rating	ATM
shipping weight	approx. 30 lb (14 kg)

sentry-equip.com

966 Blue Ribbon Circle North, Oconomowoc, WI 53066 U.S.A. | +1-262-567-7256 | sales@sentry-equip.com

© 2016 Sentry Equipment Corp. All rights reserved. All product and company names are property of their respective owners. It is solely the responsibility of end users, through their own testing and analysis, to select products and materials suitable for their specific application requirements, ensure they are properly installed, safely applied and properly maintained, and to limit their use to their intended purpose. Improper selection, installation or use may result in personal injury or property damage.

S-SP-SPS-00167-8 6-16



COMPANY WITH
QUALITY SYSTEM
CERTIFIED BY DNV GL
= ISO 9001 =