



Gas



Liquid & Slurry



Solid & Powder



Steam & Water

SENTRY HPR SAMPLER

Point Samplers

AUTOMATIC SAMPLING

The Sentry® HPR point sampler automates sampling of free-flowing materials such as granules, powders, flakes or pellets from positive or negative pressure systems. A point sampler captures samples from a point in a process stream and often is used when the material is homogenous.

To obtain a sample, the Sentry HPR sampler's air cylinder moves a sample probe into the process stream. The material sampled is discharged through a flexible hose to a collection point. Material characteristics are not affected by the sampler because no moving parts convey the sample material to the sample container. Sample volume can be changed (reduced) via the sampler controller.

MODEL

HPR

BENEFITS

The Sentry HPR point sampler combines proven representative sampling technology with a hygienic, fast-clean design that nearly eliminates the potential for bacterial build up. With representative sampling, characteristics of each sample match that of the entire lot or batch—so samples are repeatable, leading to accurate sample analysis data. Automatic sampling ensures a sample can be obtained easily and safely with no need for direct human interface or interference. This ensures sample integrity as well as operator safety.

FEATURES

- Customized to meet various application needs
- Tube retracts from the line to avoid any restriction in product flow
- Wetted components are 300 series stainless steel & food grade plastic
- UHMW or PTFE seals
- FKM food grade gaskets
- Designed to eliminate the degradation of sample material
- No moving parts in conveyance from sampler to container, keeping material characteristics consistent
- Stroke lengths of 4, 6 and 8 inches (102, 152 and 203 mm)
- CE and ATEX compliant models available
- Includes air filter, regulator and gauge where applicable
- Custom mounting adapters available for round, square or other shaped chutes or pipes



Sample. Monitor. Measure.



SENTRY

Any Application. Anywhere.

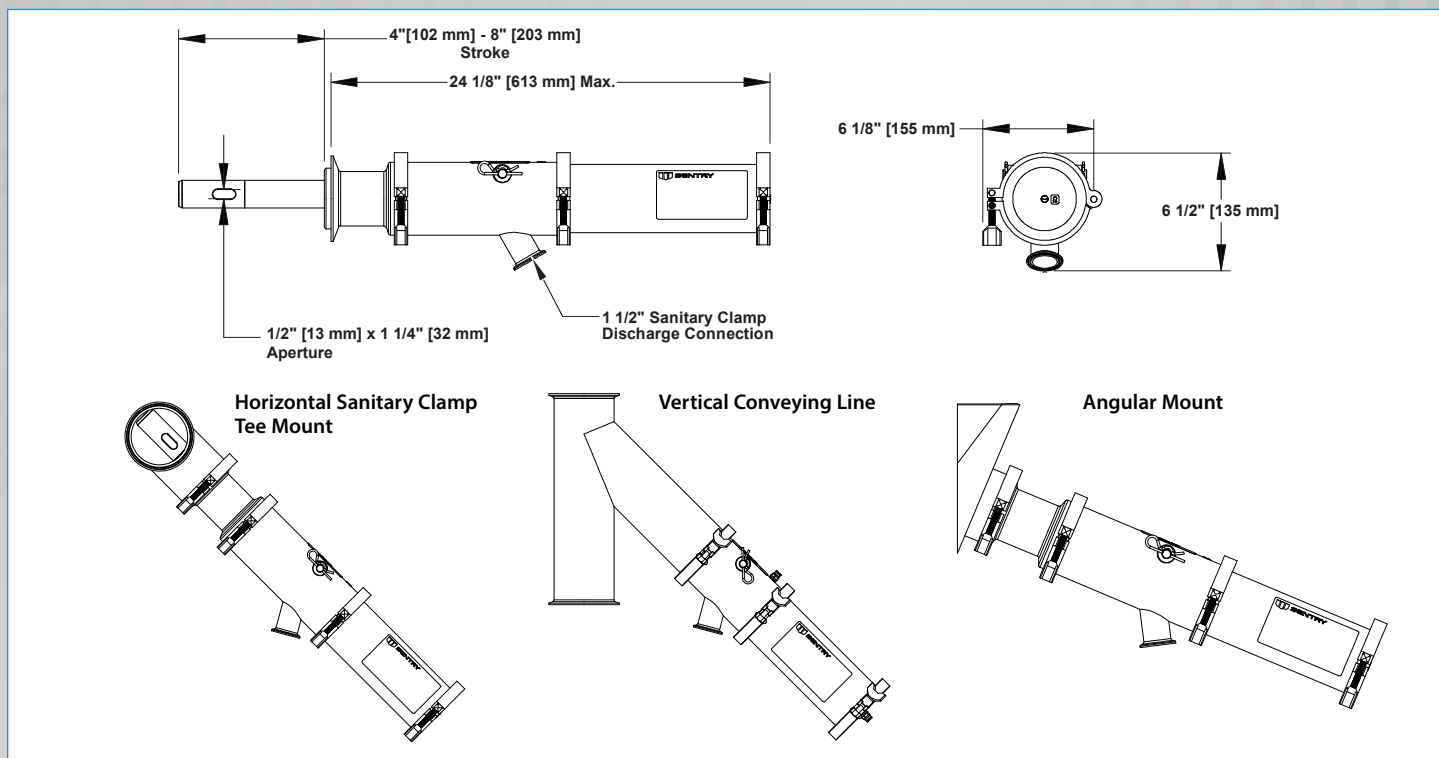

SPECIFICATIONS	
materials	300 series stainless steel, UHMW-PE, PTFE, FKM, anodized aluminum
contact surfaces	316 stainless steel; max 32 Ra finish
seal certifications	FDA & EC 1935/2004
particle size	10 µm to 1/4 in (6 mm)
temperature rating	-10 to 175°F (-23 to 79°C)
air requirements	air pressure 60 to 80 psi (4.1 to 5.5 bar) recommended; air usage 81 in ³ (1327 cc) per inch of stroke
suggested connection to sample discharge	rigid metal or flexible tubing to a collection container or indexing cabinet
recommended sampler location	positive or negative, horizontal or vertical dilute phase pneumatic conveying systems, gravity spouts
quantity of sample	determined by flow rate and mounting configuration
collection containers	PET jar, 304 stainless steel jar, bag
pressure rating	up to 30 psi (2.1 bar) standard
shipping weight	approx. 45 lb (20 kg)

sentry-equip.com

966 Blue Ribbon Circle North, Oconomowoc, WI 53066 U.S.A. | +1-262-567-7256 | sales@sentry-equip.com

© 2016 Sentry Equipment Corp. All rights reserved. All product and company names are property of their respective owners. It is solely the responsibility of end users, through their own testing and analysis, to select products and materials suitable for their specific application requirements, ensure they are properly installed, safely applied and properly maintained, and to limit their use to their intended purpose. Improper selection, installation or use may result in personal injury or property damage.

S-SP-SPS-00485-0 11-16



COMPANY WITH
QUALITY SYSTEM
CERTIFIED BY DNV GL
= ISO 9001 =