



Gas



Liquid & Slurry



Solid & Powder



Steam & Water

# SENTRY ISOLOK API-CE SAMPLER

## Point Samplers

### AUTOMATIC SAMPLING

The Sentry® ISOLOK® API-CE sampler is an anvil piston instrument (API) cell sampler specifically designed to handle the most demanding hydrocarbon liquid applications. By taking full advantage of all the benefits of bypass or fast loop sampling systems, the ISOLOK API-CE sampler is ideally suited for sampling a variety of liquids, especially crude oil, and mixtures of oil and water. The ISOLOK API-CE sampler employs an electric actuator for applications in which pneumatics are not available, and is ideal for energized mixing and blending applications.

### MODEL

ISOLOK API-CE

### BENEFITS

The electrically actuated ISOLOK API-CE sampler optimizes the accuracy and repeatability of hydrocarbon fluid sampling. The sampler offers superior performance across a wider process pressure and viscosity range and a long life, minimizing maintenance, accessories and service time needed.

The optional diamond-like carbon (DLC) coating enhances resistance against H<sub>2</sub>S, mercaptans, SO<sub>2</sub>, mercury and more.

### FEATURES

- Provides a consistent fixed volume, employs a scotch yoke design, and features next generation seal design
- Standard rate of 20 samples per minute
- Available in standard 316 stainless steel or Super Duplex steel wetted materials
- ATEX rated and complies with API 8.2, ISO 3171 and ASTM D 4177 standards
- Flow-through, bottom discharge design
- **Options:** Diamond-like carbon (DLC) coating; insertion & retraction tools



Sample. Monitor. Measure.

# SENTRY

Any Application. Anywhere.

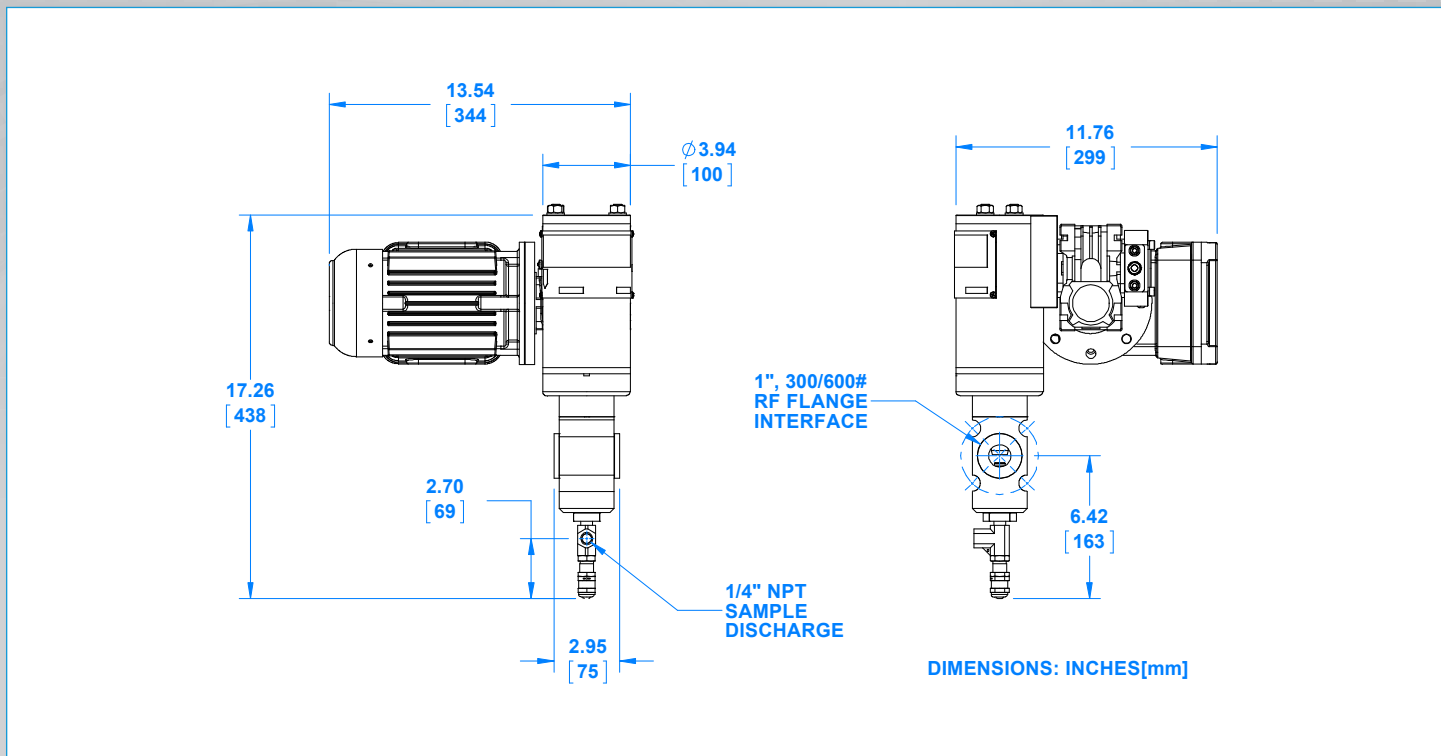

### SPECIFICATIONS

viscosity range	0.5–8000 cSt
wetted materials	316 stainless steel standard (optional Super Duplex)
optional coating on wetted parts	DLC (diamond-like coating) by DCD (dynamic compound deposition)
seal materials	carbon-filled PTFE seals with Viton® O-rings (others available)
seal temperature	-4°F to 500°F (-20°C to 260°C)
pressure rating	1500 psig at 100°F (103 barg at 38°C)
sample size (nominal)	1 cc per sample
grab sample repeatability	±2%
sampling rate	20 samples per minute
flanges	1 in Class 300/600 RF
weight (approximate)	60 lb (27 kg)
utilities required	220-230 VAC, 50/60 Hz, 2.72 A, 0.63 kW
ATEX rating	CE Ex h IIB T4...T2 Gb -20°C<Ta<+55°C

[sentry-equip.com](http://sentry-equip.com)

966 Blue Ribbon Circle North, Oconomowoc, WI 53066 U.S.A. | +1-262-567-7256 | [sales@sentry-equip.com](mailto:sales@sentry-equip.com)

© 2019 Sentry Equipment Corp. All rights reserved. Sentry is a registered trademark of Sentry Equipment Corp. Viton is a registered trademark of E. I. du Pont de Nemours and Company. It is solely the responsibility of end users, through their own testing and analysis, to select products and materials suitable for their specific application requirements, ensure they are properly installed, safely applied and properly maintained, and to limit their use to their intended purpose. Improper selection, installation or use may result in personal injury or property damage.

S-AS-SPS-00418-9 05-21



COMPANY WITH  
QUALITY SYSTEM  
CERTIFIED BY DNV GL  
= ISO 9001 =