



Gas



Liquid & Slurry



Solid & Powder



Steam & Water

SENTRY VREL CONTROL VALVE

Pressure Conditioning

SAMPLE CONDITIONING

Chemical analysis of water and steam samples in modern power generation plants requires precise control of flow and pressure. However, high-pressure reduction needs can present sampling problems. The patented Sentry® VREL® control valve is specifically designed to solve unique high-pressure sampling issues.

The Sentry VREL control valve consists of two stainless steel tubes joined to a large tube or barrel. A tapered rod assembly is inserted into precision holes in the barrel. The high pressure fluid enters, flows past one rod, turns and flows past the other rod, and then out. Pressure drop is a function of the length of the rods inserted into the barrel. The pressure is reduced smoothly under laminar flow conditions, minimizing dissociation of any components through discontinuous pressure drops. The rod position is controlled externally by turning the knob, and can be adjusted while sample is flowing. If blockage occurs, the rods can be retracted so system pressure can blow the solid matter through.

The Sentry VREL control valve is the industry standard for samples greater than 500 psig (34.5 barg) according to the Annual Book of ASTM Standards, ASTM Designation D3370.

MODEL

VREL

BENEFITS

The Sentry VREL control valve's adjustable rod-in-tube design allows for variable pressure drop and flow control. Plus, unlike other valves, the VREL control valve is cleanable in place without shutdown of the sample line. Since corrosion products, scale and other foreign matter often find their way into sample lines, plugging of the pressure reduction valve is common, and the sample line must be shut down while the valve is removed for cleaning or replacement. However, if the Sentry VREL control valve plugs with solids, the rods can be fully retracted and the obstruction blown free without disconnecting any lines. The analyzer can be returned to service in minutes.

Both of these design advantages provide consistent sample conditioning.

And, when source pressures change, such as at startup and shutdown, the Sentry VREL control valve can be easily adjusted to allow continuous monitoring under all pressure conditions.

FEATURES

- Ergonomic speed handle substantially reduces turning effort
- No valve/regulator erosion or wire drawing
- Fine flow control
- Fully retractable rods assure easy online purging
- Extended-body design eliminates possibility of bent tubes
- Flows from 150 milliliters per minute up to 4 liters per minute at pressure drops up to 5000 psig (345 barg) standard, and 7803 psig (538 bar) for supercritical power plant applications



Manufactured under one or more U. S. patents: RE37,153



Sample. Monitor. Measure.

SENTRY

Any Application. Anywhere.

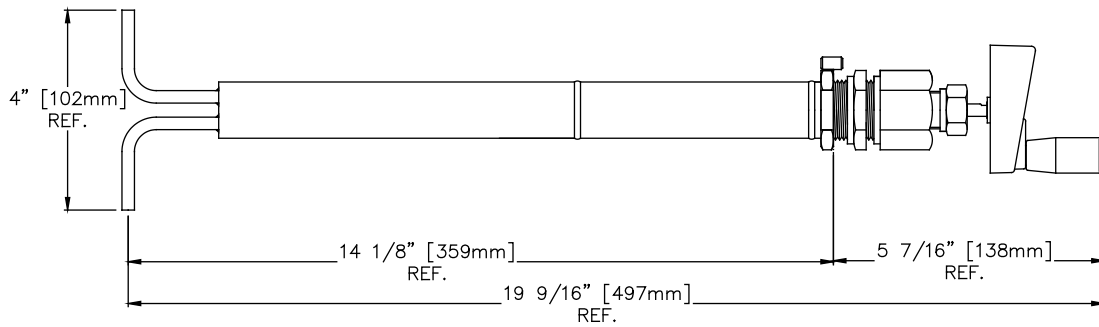

SPECIFICATIONS

pressure rating	5000 psig at 300°F (345 barg at 149°C)
standard end connection	1/4 in (6.4 mm) OD bare tube ends; other options available
wetted materials	316 SS
shipping weight	4 lb (2 kg)

NOTE: The Sentry VREL control valve is not a shut-off valve. The minimum flow that can be obtained is approximately 150 cc per minute.

sentry-equip.com

966 Blue Ribbon Circle North, Oconomowoc, WI 53066 U.S.A. | +1-262-567-7256 | sales@sentry-equip.com

© 2017 Sentry Equipment Corp. All rights reserved. All product and company names are property of their respective owners. It is solely the responsibility of end users, through their own testing and analysis, to select products and materials suitable for their specific application requirements, ensure they are properly installed, safely applied and properly maintained, and to limit their use to their intended purpose. Improper selection, installation or use may result in personal injury or property damage.

S-SW-SPS-00122-20 1-17



COMPANY WITH
QUALITY SYSTEM
CERTIFIED BY DNV GL
= ISO 9001 =