

Installation, Operation & Maintenance Manual

Sentry BPRV Back Pressure Regulator Pressure Conditioning

S-SW-IOM-00247-3 4-18

sentry-equip.com

966 Blue Ribbon Circle North, Oconomowoc, WI 53066 U.S.A. | +1-262-567-7256 | support@sentry-equip.com

 COMPANY WITH
 QUALITY SYSTEM
 CERTIFIED BY DNV GL
 = ISO 9001 =

Standard Warranty

Sentry Equipment Corp ("Seller") warrants products manufactured by it and supplied hereunder ("Products") to be free from defects in workmanship and, to the extent materials are selected by Seller, to be free from defects in materials, in each case for a period as defined in the table below:

Brand	Product Line	Warranty Period
Sentry®	1. Automatic Sampling 2. Corrosion Monitoring 3. Manual Sampling 4. Sample Conditioning 5. Sampling & Analysis Systems 6. Replacement Parts (without expiration dates)	Eighteen months from date of shipment or twelve months from startup, whichever occurs first
Waters Equipment	1. Sampling & Analysis Systems 2. Replacement Parts (without expiration dates)	Twelve months from date of shipment

To view the full warranty, go to www.sentry-equip.com/warranty.



Do not install, maintain, or operate this equipment without reading, understanding, and following the appropriate Sentry Equipment Corp instructions. Otherwise, injury, damage, or both may result.

Copyright

© 2018 by Sentry Equipment Corp. All rights reserved. All product and company names are property of their respective owners. This document contains proprietary information. No part of this document may be photocopied or reproduced without the prior written consent of Sentry Equipment Corp.

Limit of Liability

Sentry Equipment Corp, its employees, agents, and the authors and contributors to this document specifically disclaim all liabilities and warranties, express or implied (including warranties of merchantability and fitness for a particular purpose), for the accuracy, currency, completeness, and/or reliability of the information contained herein and/or for the fitness for any particular use and/or for the performance of any material and/or equipment selected in whole or part with the user of or in reliance upon information contained herein. Selection of materials and/or equipment is at the sole risk of the user of this publication.

Note

The information contained in this document is subject to change without notice.

Safety Information

Please read the entire manual before attempting to unpack, set up, or operate this product. Pay careful attention to all Warnings, Cautions, and Notes. Failure to do so could result in serious personal injury and/or equipment damage.

Use of Hazard Information

If multiple hazards exist, the signal word corresponding to the greatest hazard shall be used.

Definitions

⚠ DANGER

DANGER indicates a hazardous situation which, if not avoided, will result in death or serious injury.

⚠ WARNING

WARNING indicates a hazardous situation which, if not avoided, could result in death or serious injury.

⚠ CAUTION

CAUTION, used with the safety alert symbol, indicates a hazardous situation which, if not avoided, could result in minor or moderate injury.

NOTICE

NOTICE is used to address practices not related to personal injury.

📌 NOTE

Information that requires special emphasis.

📌 TIP

Alternate techniques or clarifying information.

SHALL: This word is understood to be mandatory.

SHOULD: This word is understood to be advisory.

General Safety Precautions

Product Selection, Installation, and Use

⚠ WARNING

Improper selection, installation, or use can cause personal injury or property damage. It is solely the responsibility of users, through their own analysis and testing, to select products suitable for their specific application requirements, ensure they are properly maintained, and limit their use to their intended purpose.

Follow proper local, state, and federal regulations for proper installation and operational requirements.

Always use caution and common sense when working with any chemical. Read the product label and Material Safety Data Sheets (MSDS) carefully and follow the instructions exactly.

Potential Equipment Hazards

⚠ WARNING

Hot surfaces! This equipment may have very hot surfaces. If an operator contacts a hot surface, injury may occur. Use protective clothing to prevent injury. If other equipment comes in contact with a hot surface, damage to the equipment may occur. Ensure the area around this equipment is kept clear to prevent this damage from occurring.

High pressures! This equipment may contain fluids at very high pressures. Prior to installing, removing, or maintaining this equipment, ensure that the equipment is isolated from all connecting piping, the equipment is depressurized, the contents have been drained, and the equipment is cool.

General Description

When installed in a system as shown in Figure 1, the Sentry® Back Pressure Regulator/Relief Valve (BPRV) holds a constant pressure of approximately 20 psig (1.4 barg) at the analyzer inlet. This pressure is maintained independent of source pressure fluctuations or sample flow changes. If inlet pressure rises, the regulator opens to let excess flow pass through to drain. This flow is usually used as the grab sample. This unit also acts as a relief valve in the event of an over-pressure condition.

Installation

The Sentry BPRV should be installed in sequence according to Figure 1. The BPRV only has to control pressure between 20 psig (1.4 barg) and atmosphere. This allows very precise pressure control, minimizes plugging and ensures reliability. Connections on the BPRV are ¼" NPT Female and wetted materials are 316 SS and Viton®.

Operation

In the normal mode of operation, there should always be a flow from the exhaust port. This flow will increase with rising source pressures and decrease with falling source pressures, unless the Sentry VREL® valve is reset to maintain the total line flow at the set point. The Sentry BPRV also functions as a fail safe relief valve. The relieving capacity exceeds that of the most commonly used 1/4" relief valve. Since the BPRV is always in service, a malfunction is immediately evident. A relief valve can freeze with no outward indication until it fails to operate in an emergency.

Maintenance

Basic maintenance of the BPRV generally consists of cleaning and/or replacement of the diaphragm. Follow the directions below to disassemble and reassemble the BPRV for maintenance.

⚠ CAUTION

The BPRV is spring loaded. Do not remove the six screws that hold the housing to the valve body without first reading these instructions completely.

Required Materials

- #2 Phillips screwdriver
- #8-32 x 3" screws (qty 3)
- Safety glasses
- Torque wrench

Disassembly & Reassembly

1. Remove three (3) of the six (6) #8-32 x 1/2" screws which hold the spring housing to the body. The screws that are removed should be 120 degrees apart (figure 2).
2. Replace the three (3) 1/2"-long screws with three (3) #8-32 x 3" screws, tightening them until the screw heads bottom out on the body flange.
3. Remove the three (3) remaining 1/2"-long screws.
4. Alternately loosen the 3"-long screws until compression is relieved from spring.
5. Clean or replace parts as required.
6. For re-assembly, reverse the above procedure using the 3"-long screws as jack screws to reapply compression to the spring.
7. Check the tightness of all six (6) screws with a torque wrench. Alternate from one side to the other, until all six are tightened to 16 in-lb (1.8 Nm).

Figure 2.

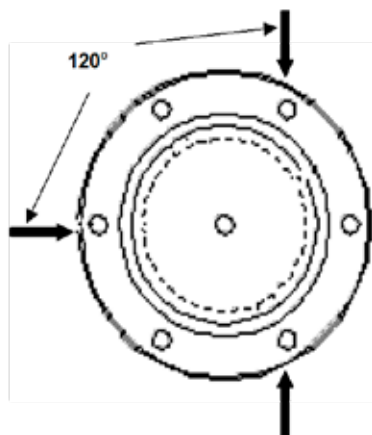
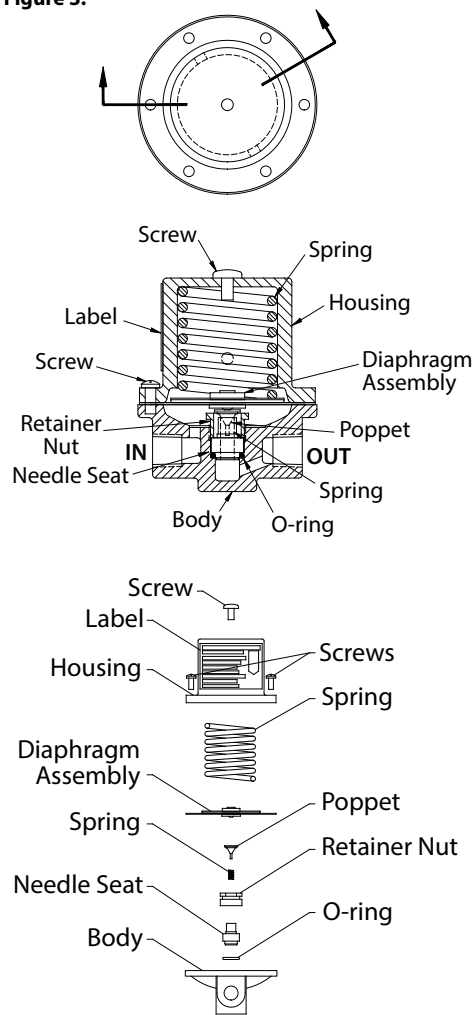

Figure 3.



Spare Parts List

6-04084A – BPRV Diaphragm Replacement Kit

Customer Support

With proven sampling expertise since 1924, Sentry products and services provide business operations the critical insights to optimize process control and product quality. We deliver true representative sampling and analysis techniques to customers around the globe, empowering them to accurately monitor and measure processes for improved production efficiency, output, and safety. Standing behind our commitments, we are determined to tackle any application, anywhere.

We know that running an efficient operation isn't easy. It requires thorough, careful analysis of controlled, real-time data achieved through reliable, accurate, and repeatable process monitoring and measuring. By effectively conditioning, sampling, and measuring gas, liquid, slurry, powder, solids, steam, or water within their production environments, our customers obtain the critical insights they need to control and optimize their processes.

Yet, controlling your processes also means reliable customer support throughout the life cycle of your equipment.

- Customer Service—General information, warranty claims, order management.
- Installation Service—For systems that require specialized expertise upon installation.
- Technical Support—Troubleshooting, training, and technical manuals.
- Field Service & Retrofits—When a problem needs immediate attention.
- Replacements Parts & Consumables—Order your replacement parts and consumables.
- Sentry ProShield Services—Select from four ProShield Guardian service plans providing different levels of support to protect your large system investments with regularly scheduled maintenance.

To learn more, go to www.sentry-equip.com/support.