



Gas



Liquid & Slurry



Solid & Powder



Steam & Water

SENTRY ISOLOK SAK SAMPLER

Point Samplers

AUTOMATIC SAMPLING

The Sentry® ISOLOK® SAK automatic point sampler provides a simple, reliable means of collecting representative samples of flowable powders, flakes or granules. Materials such as salt, cement, fertilizer, alumina, gypsum, and food products are sampled from process streams. An auxiliary top body port enables air ejection of non-free-flowing materials.

An air cylinder extends a single plunger into the process material, then immediately withdraws, carrying a fixed amount of sample trapped in an annular ring between plunger seals. Process or flow ports are always closed, preventing leaks or product loss. There are no tubes or passages to become clogged. The gravity-discharged sample is transferred directly to a closed container.

MODELS

ISOLOK SAK

BENEFITS

The Sentry ISOLOK SAK sampler seal design isolates the operator from the process at all times, with the sample captured in the container "locked out" from external influences.

The samplers can be used for composite, batch or analysis sampling techniques. Composite sampling is accomplished by obtaining a series of precisely measured material samples at set intervals or adjusted in response to product flow. Samples can be collected in shared or individual containers. Batch or analysis sampling in response to immediate need or on-line process control interface is facilitated using single or rapid-cycling material withdrawal.

A complete line of programmable automatic sampler controllers is available for use in general purpose as well as hazardous environments.

FEATURES

- Collects samples from slide or vertical drop chutes or direct from open processes
- Single moving part collects accurate and repeatable 16 or 18 cc sample volume
- Simple gravity-discharge design for powder, flakes or pellets up to 11/32 inch (9 mm) without shearing or degrading sample material
- Rugged 316 stainless steel construction
- Field-replaceable, application-specific seals include EPDM, polyurethane elastomers and more
- Tri-clamp mating ferrules and 2-inch (5 cm) smooth-bore mounting port for easy installation and maintenance
- ATEX-compliant models available



Sample. Monitor. Measure.

SENTRY

Any Application. Anywhere.

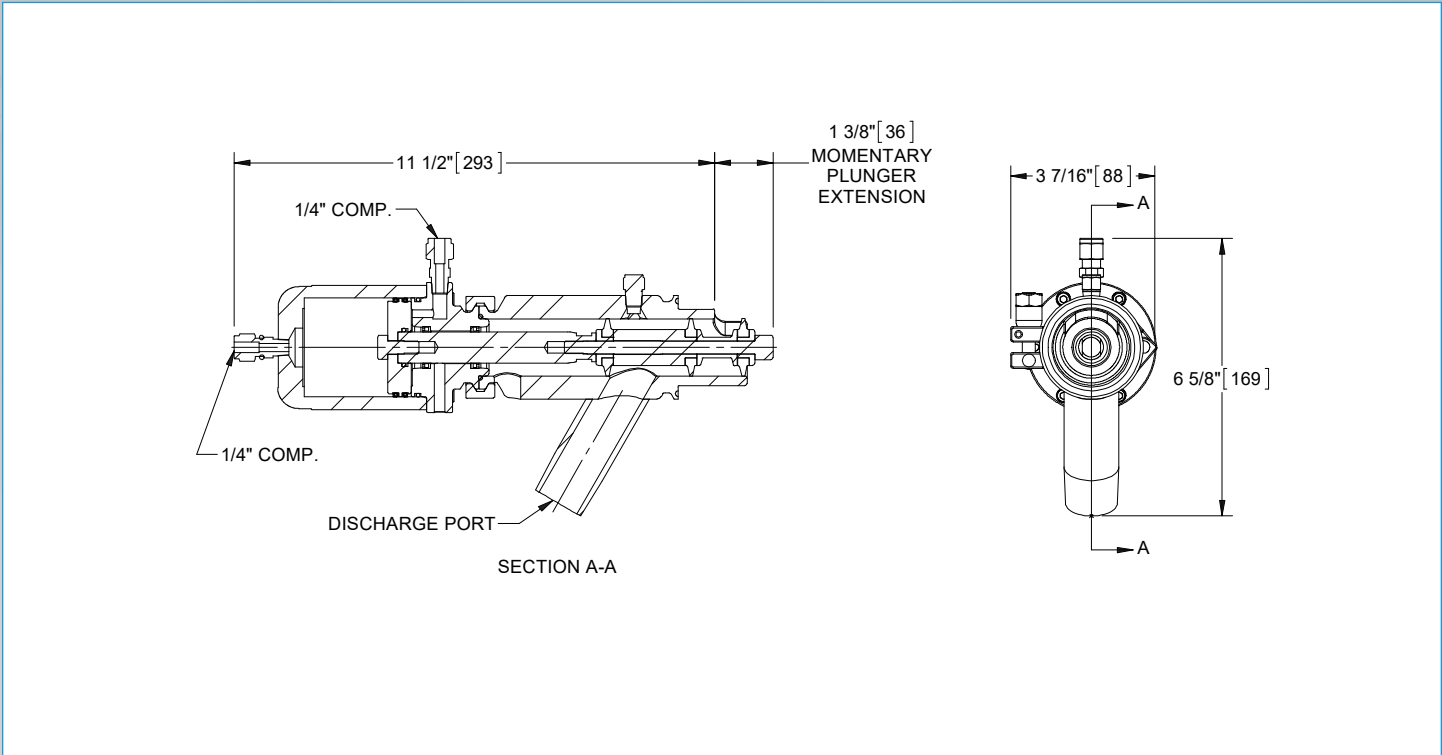

SPECIFICATIONS

sample volume per cycle	16 or 18 cc
maximum particle size	0.34 in (9 mm)
maximum cycle frequency	15 strokes per minute, depending on application
materials	316 stainless steel; other materials available
actuator seals	filled Teflon®; other materials available
static seals	fluoroelastomer; other materials available
plunger seals	filled Teflon, polyurethane, EPDM rubber; other materials available
sample temperature range	-40°F to 575°F (-40°C to 302°C), depending on seal material and duty cycle
ambient operating temperature range	-5° to 131°F (-20° to 55°C) depending on seal material
line mount adapter type	2 in (50 mm) clamp ferrule
compressed air requirement	2 SCFM at 30 to 80 psig (2.1 to 5.5 barg)
dimensions	10.44 in x 3 in (26.5 cm x 7.6 cm)
shipping weight	10 lb (4.5 kg)

Teflon is a registered trademark of E. I. Du Pont de Nemours and Company.

sentry-equip.com

966 Blue Ribbon Circle North, Oconomowoc, WI 53066 U.S.A. | +1-262-567-7256 | sales@sentry-equip.com

© 2019 Sentry Equipment Corp. All rights reserved. All product and company names are property of their respective owners. It is solely the responsibility of end users, through their own testing and analysis, to select products and materials suitable for their specific application requirements, ensure they are properly installed, safely applied and properly maintained, and to limit their use to their intended purpose. Improper selection, installation or use may result in personal injury or property damage.

S-AS-SPS-00193-8 01-19



COMPANY WITH
QUALITY SYSTEM
CERTIFIED BY DNV GL
= ISO 9001 =