



Gas



Liquid & Slurry



Solid & Powder



Steam & Water

SENTRY RPG SAMPLER

Point Samplers

AUTOMATIC SAMPLING

The Sentry® RPG automatic point sampler automates sampling of dry free-flowing materials such as granules, powders, flakes or pellets from gravity chutes and hoppers. A point sampler captures samples from a point in a process stream and often is used when the material is homogenous.

To obtain a sample, the Sentry RPG sampler's air cylinder moves a sample probe into the process stream. Once fully extended, an air actuator rotates the sample chamber into the upright position. The air cylinder then retracts the sample tube. The rotary actuator rotates the sample chamber to the down position and the sample material is discharged through a flexible hose to a collection point. Sample characteristics are not affected by the sampler because no moving parts convey the product to the sample container. Sample volume can be changed at the sampler controller.

MODELS

RPG

BENEFITS

With representative sampling, characteristics of each sample match that of the entire lot or batch—so samples are repeatable, leading to accurate sample analysis data. Automatic sampling ensures a sample can be easily and safely obtained with no need for direct human interface or interference. This ensures sample integrity as well as operator safety.

FEATURES

- Customized to meet various application needs
- Tube retracts from the line to avoid any restriction in product flow
- Wetted components are 300 series stainless steel
- White nitrile seals or gaskets
- Urethane wiper seal
- Designed to eliminate the degradation of sample material
- No moving parts in conveyance from sampler to container, keeping product characteristics consistent
- Stroke lengths of 4, 6, 8, 10 and 12 inches (102, 152, 203, 254 and 305 mm)
- CE and ATEX compliant models available
- Includes air filter, regulator and gauge where applicable
- Optional release coating to ensure a non-stick surface
- QPQ hardening of contact surfaces available to protect against wear and abrasion
- Custom mounting adapters for round, square or other shaped chutes or pipes
- Optional sample tube purge
- Pre-plumbed filter/regulator and solenoid valve available
- All stainless housing and rails available

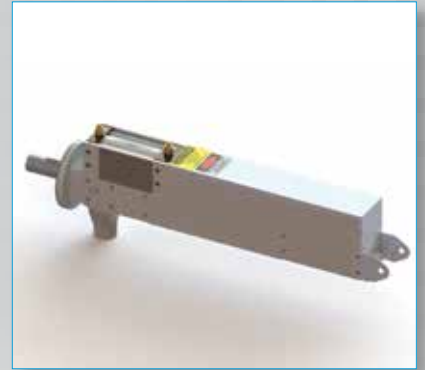

Sample. Monitor. Measure.

SENTRY

Any Application. Anywhere.

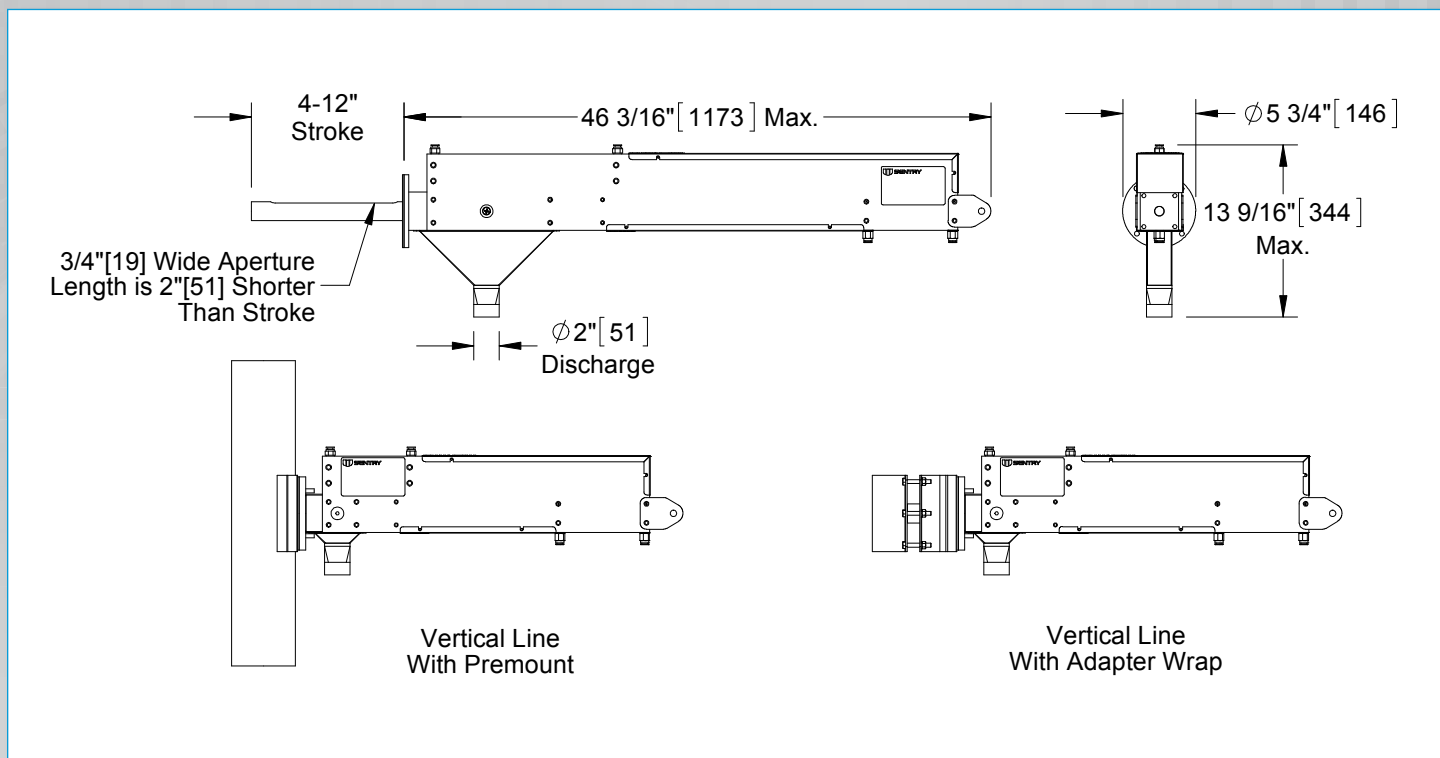

SPECIFICATIONS

materials	300 series stainless steel, urethane, nylon, acetal, white nitrile, aluminum cylinder
particle size	10 µm to 1/4 in (6 mm)
temperature rating	-10 to 175°F (-23 to 79°C)
air requirements	air pressure of 60 to 80 psi (4.1 to 5.5 bar) recommended; air usage 32 in ³ (524 cc) per inch of stroke for the air cylinder, 17 in ³ (279 cc) per inch of stroke for the air actuator
suggested connection to sample discharge	rigid metal or flexible tubing to a collection container or indexing cabinet
recommended sampler location	gravity spouts, hoppers or transfer chutes
quantity of sample	1.5 in ³ (25 cc) per cycle for a 4-inch stroke sampler; for each additional inch of stroke, add .82 in ³ (13 cc)
collection containers	PET jar, 304 stainless steel jar, bag
pressure rating	ATM
shipping weight	approx. 30 lb (14 kg) for 4-inch (102 mm) stroke to 45 lb (20 kg) for 12-inch (305 mm) stroke

sentry-equip.com

966 Blue Ribbon Circle North, Oconomowoc, WI 53066 U.S.A. | +1-262-567-7256 | sales@sentry-equip.com

© 2016 Sentry Equipment Corp. All rights reserved. All product and company names are property of their respective owners. It is solely the responsibility of end users, through their own testing and analysis, to select products and materials suitable for their specific application requirements, ensure they are properly installed, safely applied and properly maintained, and to limit their use to their intended purpose. Improper selection, installation or use may result in personal injury or property damage.

S-SP-SPS-00174-7 6-16



COMPANY WITH
QUALITY SYSTEM
CERTIFIED BY DNV GL
= ISO 9001 =