



## DS-3 SERIES CONVEYOR BELT SAMPLER

### ***Heavy Duty Sampler for Conveyor Belt Sampling***

#### ***Features***

- Heavy duty frame and drive components
- Hinged inspection doors are interlocked to prevent arm rotation if open
- A precycle warning horn signal for operator safety
- NEMA 4 enclosure for controls provides dust and weather protection

#### ***Options***

- Optional completely-enclosed sample container platforms for moisture and fines retention
- Explosion proof option includes all electrical components suitable for use in hazard rated areas:  
Class I, Division 1, Group D, or  
Class II, Division 1, Group G & F
- Open-style sample container platform with 10-gallon metal containers

#### ***Description***

With an overall height of less than 24 inches (61 cm), the low profile DS-3 sampler mounts over conveyors and allows for installation in low headroom areas. The sampler arm and drive components are mounted within a steel enclosure. The sample scoop rotates through a conic sweep path, scooping a sample from the belt, which is then pitched and poured into a large, stainless steel hopper that discharges to the side of the belt.

The DS-3 unit mounts at any convenient point along the conveyor, using heavy, bridge-type supports (included). Controls and discharge can be assembled to accommodate access from the right or the left side of the conveyor.

The standard scoop is approximately 3" (76 mm) wide and will produce from 12 cu. in. (196 cc) to 16 cu. in. (262 cc) of sample each cycle. The DS-3 sampler is available with an optional 4" (102 mm) wide sample collection scoop as well as smaller sample cutters.

Arm speed is adjustable to suit belt speeds up to 900 FPM. The arm moves in the same direction as the belt (at a slightly faster speed) collecting a sample without disrupting the material on the conveyor belt.

The arm drive system is a rugged worm gear reducer in combination with a variable speed motor drive which produces a wide range of flexibility in matching arm speed to the speed of the conveyor belt.

Cycle rates are adjustable to sample at a maximum frequency of twice per minute.

## TECHNICAL DATA

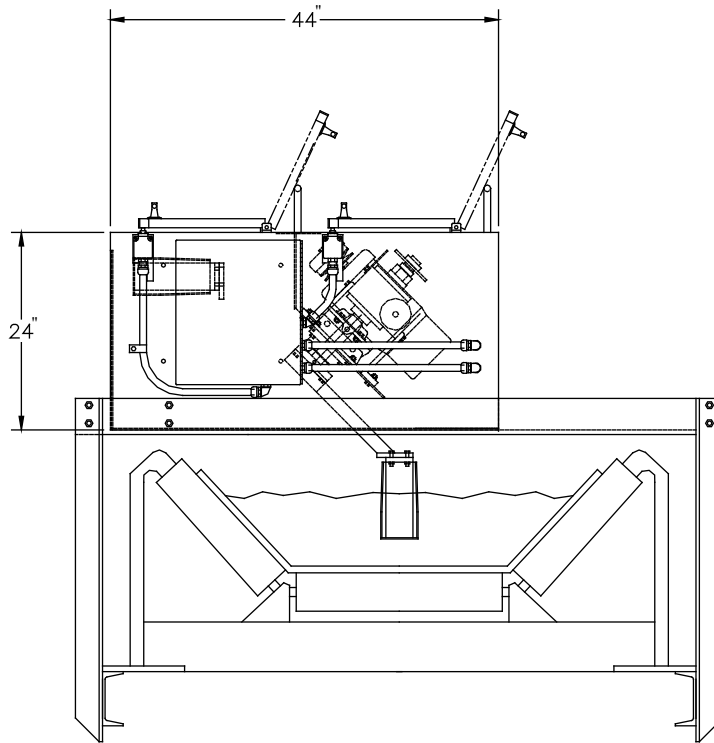

## SPECIFICATIONS

Sample Volume per Cycle . . . . .	up to 16 cu. in. / 262 cc
Maximum Particle Size . . . . .	2" / 50 mm
Basic Electrical Requirements . . . . .	230/460 VAC, 3 phase, 50/60 Hz
Maximum Belt Speed . . . . .	to 900 FPM (adjustable)
Maximum Cycle Rate . . . . .	twice (2x) per minute
Materials of Construction . . . . .	painted carbon steel enclosure w/ 300 series stainless steel hopper
Dimensions (not including bridge-type supports) . . . . .	52" x 44" x 24" / 132 cm x 112 cm x 61 cm
Net weight, std. . . . .	900 lbs. / 409 kg

### ▲WARNING

It is solely the responsibility of the end-user, through its own analysis and testing, to select products and materials suitable for their specific application requirements, ensure they are properly installed, safely applied, properly maintained, and limit their use to their intended purpose. Improper selection, installation, or use may result in personal injury or property damage.



### SENTRY EQUIPMENT CORP

PO Box 127  
Oconomowoc, WI 53066 USA  
Phone: 262-567-7256  
Fax: 262-567-4523

**E-mail:**  
sales@sentry-equip.com

**Website:**  
www.sentry-equip.com

QUALITY MANAGEMENT SYSTEM  
CERTIFIED BY DNV  
— ISO 9001:2008 —

For further information, contact: