



MODEL RPG AUTOMATIC SAMPLER

For Free-Flowing and Non-Free-Flowing Bulk Solid Materials

Features

- Designed to eliminate the degradation of product
- Versatile installation in spouts, hoppers or transfer chutes
- Product contact materials are 304 stainless steel and Teflon[®] seals

Options

- Available in stroke lengths from 4" (10 cm) to 10" (25.4 cm)
- Nickel-impregnated Teflon[®] for a non-stick surface
- Hardening treatments to protect against wear and abrasion

Description

The Model RPG is designed for automatic sampling of bulk solids such as granules, powders, flakes and pellets from spouts, hoppers or transfer chutes.

The Model RPG features an air cylinder and rotary actuator. The air cylinder pushes the sample tube into the process line. Once fully extended, the rotary actuator rotates the sample chamber into the upright position. The air cylinder then retracts the sample tube. The rotary actuator rotates the sample chamber to the down position and discharges the captured sample.

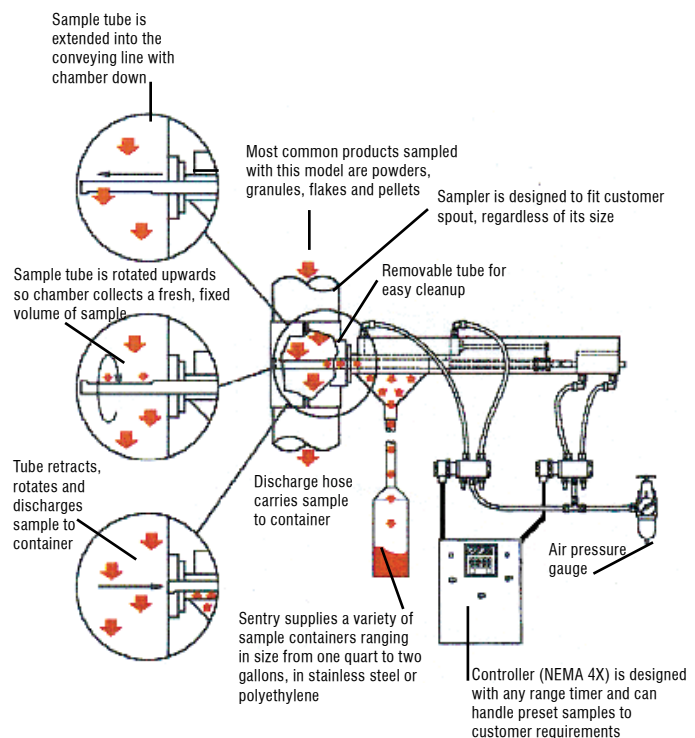

MODEL RPG TECHNICAL DATA

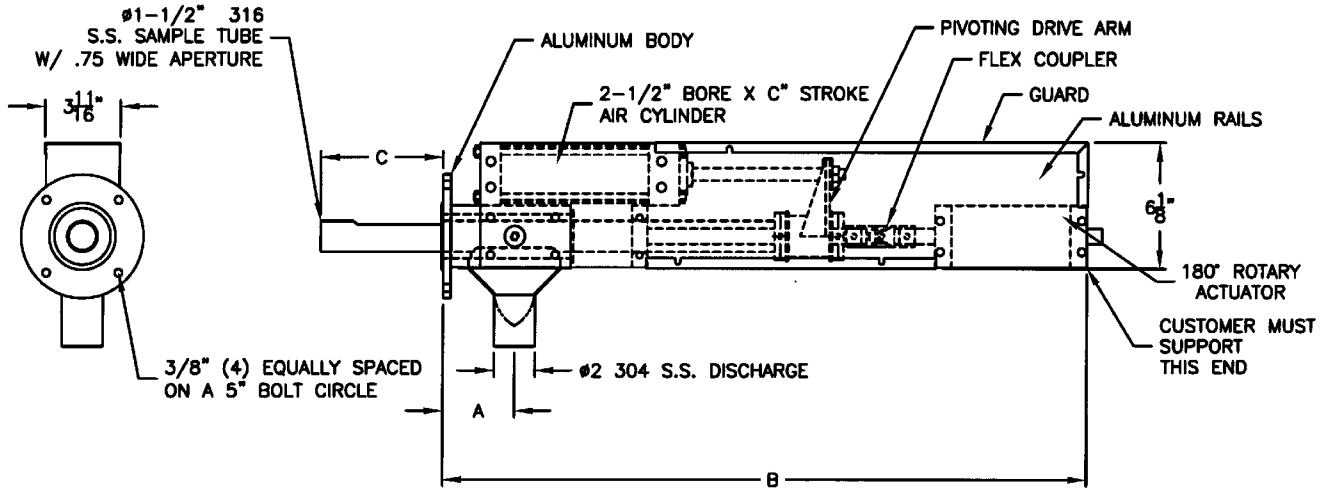

MODEL RPG*				
	4" STROKE	6" STROKE	8" STROKE	10" STROKE
A	2 1/2"	3 1/2"	4 1/2"	5 1/2"
B	27 9/16"	31 9/16"	35 9/16"	39 9/16"
C	4"	6"	8"	10"
D	4 3/8"	5 3/8"	6 3/8"	7 3/8"

* MODEL RPG MEASUREMENTS VARY, CONTACT FACTORY FOR ADDITIONAL AND/OR DIFFERENT STROKE DIMENSIONS IF REQUIRED

SPECIFICATIONS

- Basic Electrical Requirements 115/230 VAC, single phase, 50/60 Hz; control box fused to 2 amps
- Air Requirements 80 psig, 1.5 cfm per cycle
- Quantity of Sample determined by flow rate, aperture size and time in line
- Product Size 10 micron to 1/4" (6 mm); larger sizes upon request
- Recommended Location of Sampler vertical gravity lines
- Suggested Connection to Collection Point rigid metal or flexible tubing to a collection container or multi-position collection cabinet
- Materials of Construction aluminum housing and rails; 316 SS sample tube; 304 SS discharge; acetal spacers and urethane wiper seal
- Temperature Range up to 250°F (121°C)

⚠ WARNING

It is solely the responsibility of the end-user, through its own analysis and testing, to select products and materials suitable for their specific application requirements, ensure they are properly installed, safely applied, properly maintained, and limit their use to their intended purpose. Improper selection, installation, or use may result in personal injury or property damage.



SENTRY EQUIPMENT CORP

PO Box 127
Oconomowoc, WI 53066 USA
Phone: 262-567-7256
Fax: 262-567-4523

E-mail:
sales@sentry-equip.com

Website:
www.sentry-equip.com

QUALITY MANAGEMENT SYSTEM
CERTIFIED BY DNV
ISO 9001:2008

For further information, contact: