



ISOLOK[®] SERIES SAH BULK SOLIDS SAMPLER

Extended Stroke Sampler Collects Flowable Materials

Features

- Collects samples from slide or vertical drop chutes or direct from open processes
- Single moving part collects 18 cc or up to 50 cc sample volume
- Simple gravity-discharge design for powder, flakes or pellets up to 5/8" / 16 mm size
- Heavy 316 stainless steel construction features chrome-hardened body bore
- Field-replaceable, application-specific seals include EPDM, polyurethane elastomers and more
- Extended-stroke plunger ideal for sample collection inside heavy-body/double-wall vessels
- Choice of threaded instrument hub or 2.5" / 6.4 cm clamp ferrule for easy installation and maintenance



Description

ISOLOK[®] Series SAH Extended-Stroke Samplers feature a three-inch plunger stroke to collect samples inside heavy-body or double-wall vessels such as mixers, dryers and reactors. The extended body can be utilized to capture free-falling material within chutes or slide applications.

An air cylinder extends a single plunger into the process material, then immediately withdraws, carrying a fixed amount of sample trapped in an annular ring between plunger seals. Process or flow ports are always closed, preventing leaks or product loss. There are no tubes or passages to become clogged. The gravity-discharged sample is transferred directly to a closed container. Sample integrity is maintained while contamination of personnel or facility is eliminated.

ISOLOK[®] Series SAH Samplers can be used for composite, batch or analysis sampling techniques. Composite sampling is accomplished by obtaining a series of precisely measured material samples at set intervals or adjusted in response to product flow. Samples can be collected in common or individual containers. Batch or analysis sampling in response to immediate need or on-line process control interface is facilitated using single or rapid-cycling material withdrawal.

A complete line of programmable automatic controls is available for use in general purpose as well as hazardous environments.

SAMPLING PROCESS

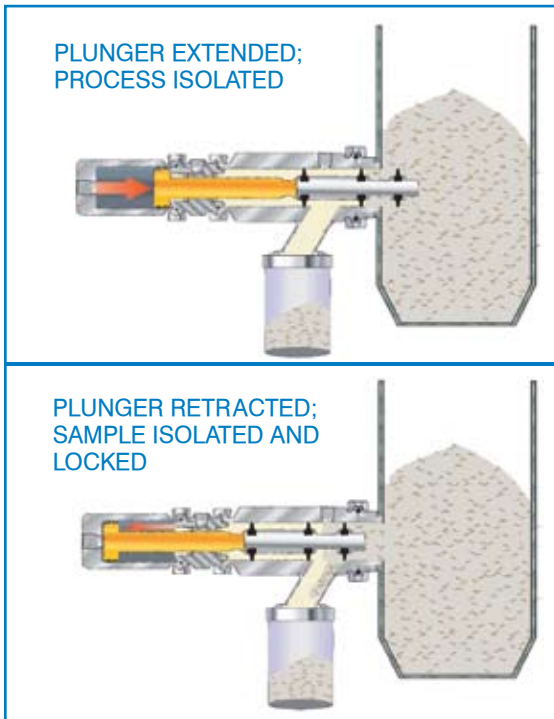

ISOLOK® SAH TECHNICAL DATA

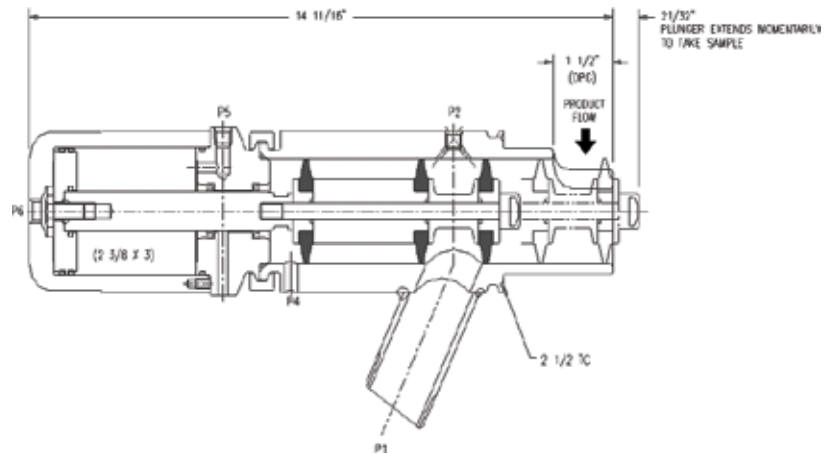

ISOLOK® SERIES SAH SAMPLER

SPECIFICATIONS

Sample Volume per Cycle	1.1 cu. in. / 18 cc or 3.0 cu. in. / 50 cc
Maximum Particle Size	0.34" / 9 mm or 0.624" / 16 mm
Operating Cycle Range	maximum 15 samples/minute
Body Material	316 stainless steel; other alloys available
Plunger Material	316 stainless steel; other alloys available
Plunger Bore x Stroke	1.375" x 3" / 35 mm x 76 mm or 1.938" x 3" / 39 mm x 76 mm
Plunger Seal Material	filled Teflon®, polyurethane, EPDM & others available
Actuator Material	316 stainless steel; other alloys available
Actuator Seal Material	filled Teflon®; others available
Static Seal Material	fluoroelastomer; others available
Sample Temperature Range	-275° to 575° F / -170° to 302° C; depending on seal material & duty cycle
Ambient Operating Temperature Range	-5° to 131° F / -20° to 55° C; depending on seal material
Line Mount Adapter Type	3.75" / 95 mm instrument hub or 2.5" / 63 mm clamp ferrule
Compressed Air Requirement	0.67 SCFM @ 30 psi / maximum cycle range
Overall Dimensions, length x diameter, less accessories	14.7" x 6.25" / 373 mm x 159 mm
Net Weight, not including controller or accessories	21 lbs. / 9.5 kg

⚠ WARNING

It is solely the responsibility of the end-user, through its own analysis and testing, to select products and materials suitable for their specific application requirements, ensure they are properly installed, safely applied, properly maintained, and limit their use to their intended purpose. Improper selection, installation, or use may result in personal injury or property damage.

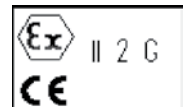

SENTRY EQUIPMENT CORP

PO Box 127
Oconomowoc, WI 53066 USA
Phone: 262-567-7256
Fax: 262-567-4523

E-mail:
sales@sentry-equip.com

Website:
www.sentry-equip.com

QUALITY MANAGEMENT SYSTEM
CERTIFIED BY DNV
ISO 9001:2008

For further information, contact: