



WSW SAMPLE COOLER

For High Viscosity/Low Pressure Drop Service

Efficient sample cooling for high viscosity liquids and slurries



WSW SAMPLE COOLER

Features

- Fully drainable helical coil
- Low pressure drop

Description

The WSW series sample cooler is designed for use in applications where drainability is critical but efficiency cannot be compromised. Its larger diameter sample tube makes it especially useful for high viscosity liquids and slurries. Optimal service for flows below 3000 cc/minute for single phase heat transfer. Standard tube side material is 316/316L stainless steel.

Performance Curve - Water

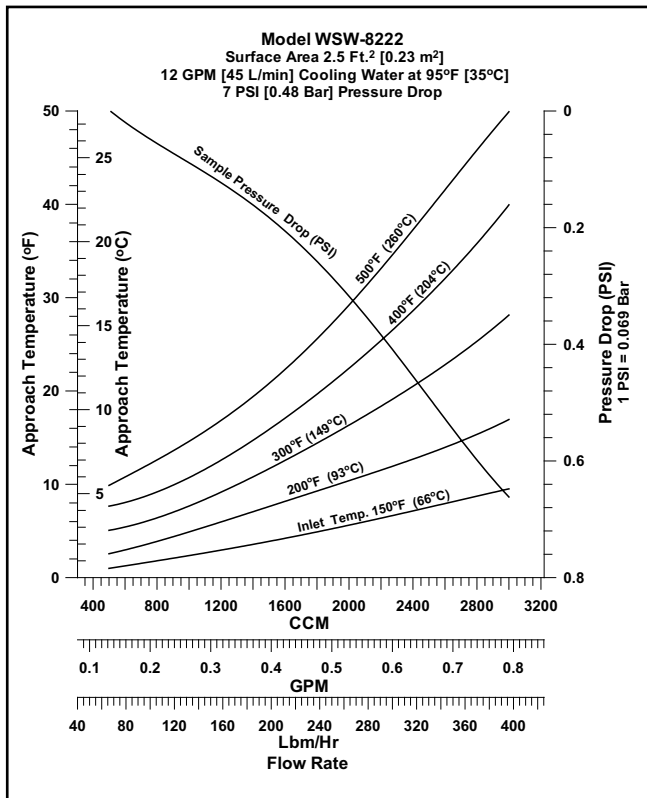

NOTE: Not recommended for steam condensing service. See TLR, FLR, FXR series sample coolers for steam applications.

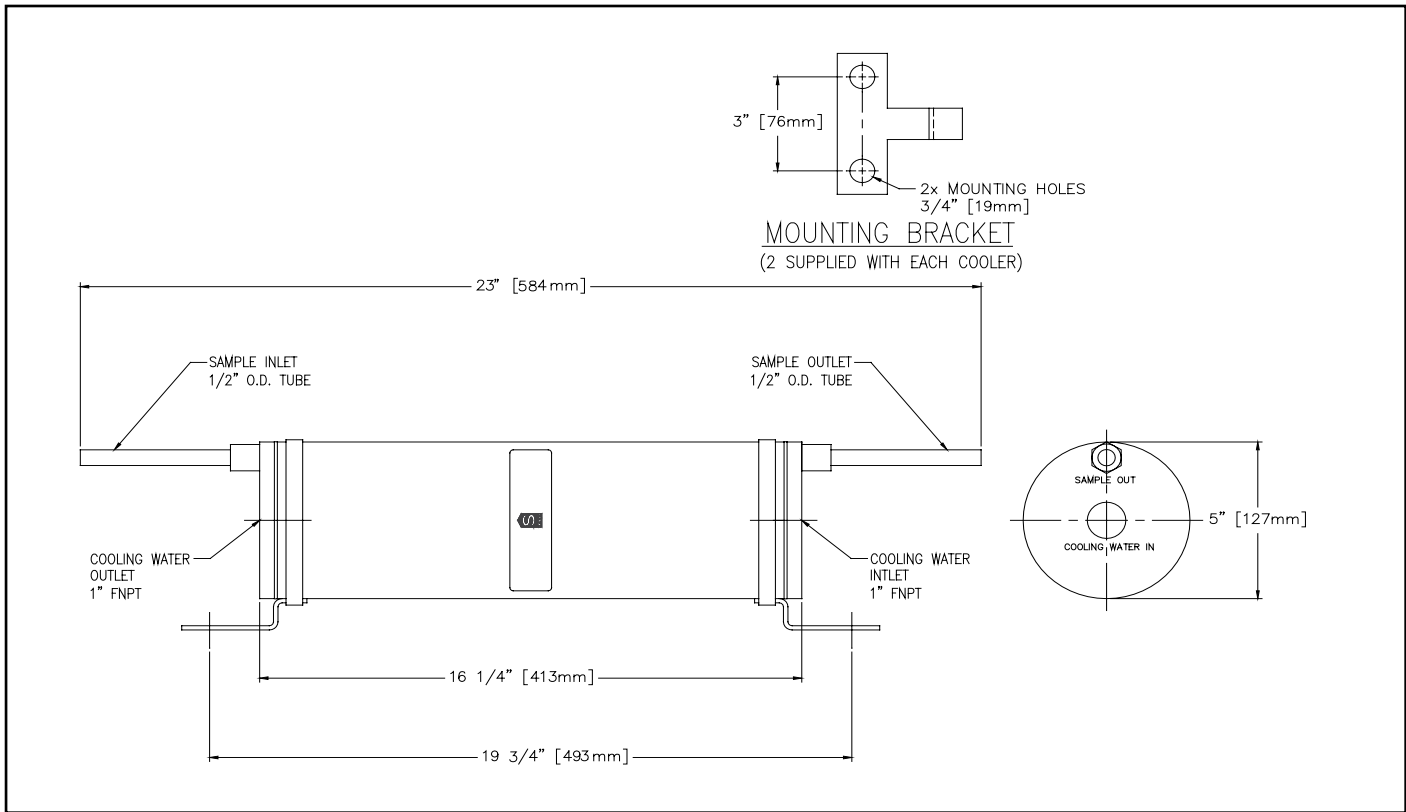

Specifications – WSW Series

Model No.	Shell Design	Tube Design	Tube Material	Shell Material	Area	Weight	Part Number
WSW-8222	400 psi @ 350°F 27 bar @ 176°C	1200 psi @ 650°F 82 bar @ 343°C	316/316L SS 1/2" O.D. x 0.035"AW	304 SS	2.5 ft ² 0.23 m ²	25 lbs 11.5 kg	7-00712A
WSW-8222U	400 psi @ 350°F 27 bar @ 176°C	1200 psi @ 650°F 82 bar @ 343°C	316/316L SS 1/2" O.D. x 0.035"AW	304 SS	2.5 ft ² 0.23 m ²	25 lbs 11.5 kg	7-00712G

- NOTE:**
- U in model number denotes ASME stamped model.
 - Canadian Registration Number available for ASME models only. Consult factory for CRN and other options and information.
 - Vessels are exempt from CE marking per PED 97/23/EC, TÜV. Vessels are below or equal to the limits set forth in Article 3, Sections 1.1, 1.2, 1.3 and Section 2 as applicable, and are designed and manufactured in accordance with sound engineering practice (meets the general requirements of the ASME Section VIII, Division 1, Boiler And Pressure Vessel Code). Nameplate will bear the name of Sentry Equipment Corp and safety instructions will be included per Article 3, Section 2.

WARNING

It is solely the responsibility of the end-user, through its own analysis and testing, to select products and materials suitable for their specific application requirements, ensure they are properly installed, safely applied, properly maintained, and limit their use to their intended purpose. Improper selection, installation, or use may result in personal injury or property damage.



SENTRY EQUIPMENT CORP

966 Blue Ribbon Circle North
Oconomowoc, WI 53066 USA
Tel: 262-567-7256 • Fax: 262-567-4523

E-mail:
sales@sentry-equip.com

Website:
www.sentry-equip.com



For further information, contact: