



SPIRAL TUBE HEAT EXCHANGER

Optimize Heat Transfer Efficiency and Space

***Compact, Efficient Heat Exchanger
for Severe Service***



Features

- Flow rates to 100 GPM (378 LPM)
- Sample conditions up to 5000 psi (345 bar) and up to 1000° F (540° C)
- Optimal design for corrosive fluid/gases
- Vapor condensing/gas stripping capabilities
- High flow in a small footprint
- Highly resistant to thermal and hydraulic shock
- Bolted or all welded shell
- Numerous flow path and connection configurations
- Compact and lightweight, easy to install

Description

A spiral tube heat exchanger is a coil assembly fitted in a compact shell that optimizes heat transfer efficiency and space. Every Sentry spiral coil assembly has welded tube to manifold joints for durability and strength. The coil assembly is welded to a head and fitted in a compact shell. The spaces or gaps between the coils of the spiral tube bundle become the shell side flow path.

The spiral shape of the flow for the tubeside and shellside fluids creates centrifugal force and secondary circulating flow that enhances the heat transfer on both sides in a true counterflow arrangement. Since there are a variety of multiple parallel tube configurations (diameter, number and length), efficiency is not compromised by limited shell diameter sizes as it is in shell and tube designs.

The profile of a spiral is very compact and fits in a smaller footprint than a shell and tube design. Since the tube bundle is coiled, space requirements for tube bundle removal are significantly reduced.

When exotic material is required, a spiral tube heat exchanger minimizes the material used since manifolds replace the channels, heads and tubesheets of a conventional shell and tube design. The shell side is usually smaller than a comparable shell and tube design and there are no requirements for tube supports or pass dividers.

CROSS SECTION OF A SPIRAL TUBE HEAT EXCHANGER

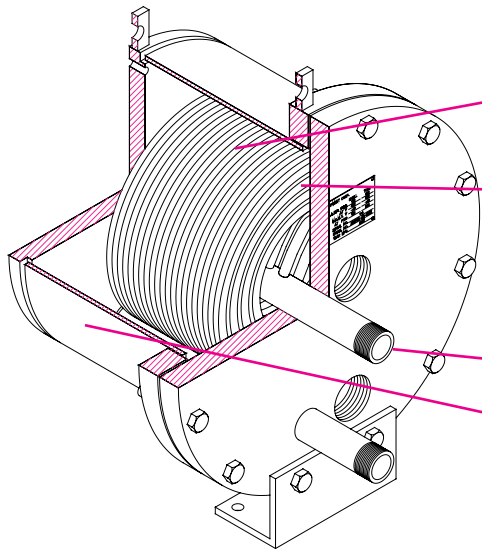

Optimized Performance

Multiple tube side parameters (diameter, length, number and material).

Variable shellside flow path gap and length.

Easy to Install

Simple piping and access.

Easy to remove shell for inspection, cleaning or replacement of tube bundle. Virtually no tube bundle pull requirement.

SPECIFICATIONS

Materials:

Shellside	Carbon Steel & Stainless Steel
Tube Bundle	Stainless Steel, Hastelloy®, Inconel® and other alloys

Standard Pressure Rating:

Shellside	150 psig (10.3 barg) @ 400° F (204° C)
Tubeside	up to 5000 psig (345 barg) @ 1000° F (540° C)

Construction:

Shellside	Bolted or welded with NPT, FLG, SW or BW connections
Tubeside	Welded tube to manifold joints with NPT, FLG, SW or BW connections

Surface Area:

1 to 177 ft² (0.1 to 16 m²)

ASME Code Stamp available upon request

TYPICAL APPLICATIONS

Pump seal coolers

Inter / After coolers

Instant hot water heaters

Sample coolers

Acid heaters/coolers

Process condensers

⚠ WARNING

It is solely the responsibility of the end-user, through its own analysis and testing, to select products and materials suitable for their specific application requirements, ensure they are properly installed, safely applied, properly maintained, and limit their use to their intended purpose. Improper selection, installation, or use may result in personal injury or property damage.



SENTRY EQUIPMENT CORP

966 Blue Ribbon Circle North
Oconomowoc, WI 53066 USA
Tel: 262-567-7256 • Fax: 262-567-4523

E-mail:
sales@sentry-equip.com

Website:
www.sentry-equip.com



For further information, contact: