

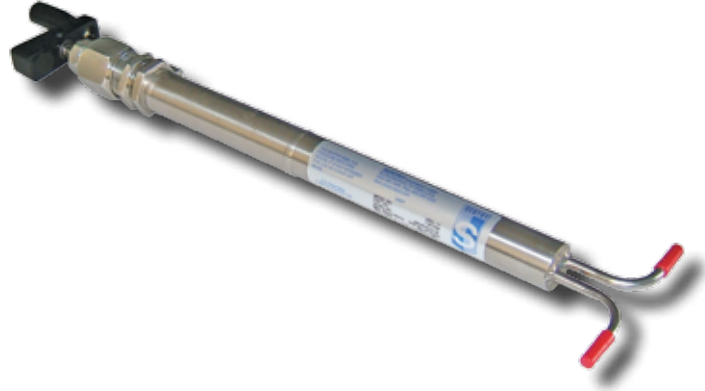

VREL[®] Variable Pressure Reducing Element

***New Heavy-Duty Speed Handle
Substantially Reduces Turning Effort***

U.S. Patent No. RE37,153



Features

- Ergonomic speed handle substantially reduces turning effort
- No valve/regulator erosion or wire drawing
- Fine flow control
- Fully retractable rods assure easy online purging
- Extended-body design eliminates possibility of bent tubes
- Flows from 150 milliliters per minute up to 4 liters per minute at pressure drops up to 5000 psig (345 barg)



**HEAVY-DUTY
SPEED HANDLE**

Description

Chemical analysis of water and steam samples in modern power generation plants requires precise control of flow and pressure. High pressure reduction presents sampling problems for the system designer. The Sentry VREL[®] is a valve specifically designed to solve unique high pressure sampling problems.

Industry Standard

The patented VREL[®] is the industry standard for samples greater than 500 psig (34.5 barg) according to the Annual Book of ASTM Standards, ASTM Designation D3370.

The adjustable rod-in-tube type design allows for variable pressure drop and flow control. The VREL[®] is also cleanable in place. Both of these design factors provide the advantages needed for consistent sample conditioning.

Adjustable

When source pressures change, such as at startup and shutdown, the VREL[®] can be easily adjusted to allow continuous monitoring under all pressure conditions.

Cleanable in Place

Since corrosion products, scale, and other foreign matter often find their way into sample lines, plugging of the pressure reduction valve is common. This is particularly true of Labrynth-type (Drag) valves, and diaphragm-operated high pressure regulators. If these valves plug, the sample line must be shut down while the valve is removed for cleaning or replacement. If the Sentry VREL[®] plugs with solids, the rods can be fully retracted and the obstruction blown free without disconnecting any lines. The analyzer can be returned to service in minutes by operating personnel.

TECHNICAL DATA

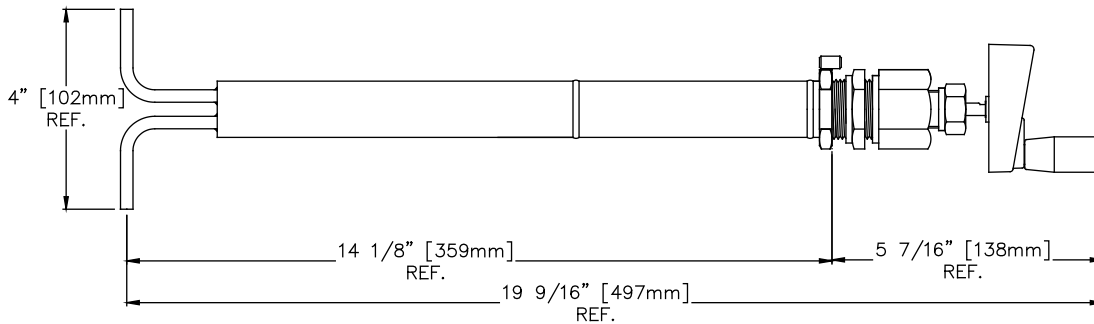

CONSTRUCTION & OPERATION

The VREL[®] consists of two stainless steel tubes joined to a large tube or barrel. A tapered rod assembly is provided and inserted into precision holes in the barrel. The high pressure fluid enters, flows past one rod, turns and flows past the other rod, then out. Pressure drop is a function of the length of the rods inserted into the barrel.

The pressure is reduced smoothly under laminar flow conditions, minimizing dissociation of any components through discontinuous pressure drops. The rod position is controlled externally by turning the knob, and can be adjusted while the sample is flowing. If blockage occurs, the rods can be retracted so that system pressure can blow the solid matter through.

SPECIFICATIONS

Wetted Materials 316 stainless steel
 Weight 4 lbs. (2 kg)
 Ratings 5000 psig at 300°F (345 barg at 149°C)
 Standard end connection 1/4" (6.4 mm) O.D. bare tube ends

Optional end connections are listed below.

NOTE: The VREL[®] is not a shut off valve. The minimum flow which can be obtained is approximately 150 cc/min.

PART NUMBERS

1/4" Plain Ends 7-00744A
 1/4" Plain Ends CRN 7-00964A
 1/4" Socket Weld 7-00747A
 3/8" Socket Weld 7-00748A
 1/2" Socket Weld 7-00749A
 1/4" 37° Fitting 7-00745A
 3/8" 37° Fitting 7-00746A

Spare Parts:

Handle and Rod Kit 6-02302E
 Seal Kit 6-02302C

⚠ WARNING

It is solely the responsibility of the end-user, through its own analysis and testing, to select products and materials suitable for their specific application requirements, ensure they are properly installed, safely applied, properly maintained, and limit their use to their intended purpose. Improper selection, installation, or use may result in personal injury or property damage.



SENTRY EQUIPMENT CORP

966 Blue Ribbon Circle North
 Oconomowoc, WI 53066 USA
 Tel: 262-567-7256 • Fax: 262-567-4523

E-mail:
 sales@sentry-equip.com

Website:
 www.sentry-equip.com



For further information, contact: