

KREBS®

PUMPS, CYCLONES AND VALVES

hMAX pump

Horizontal recessed
impeller pump

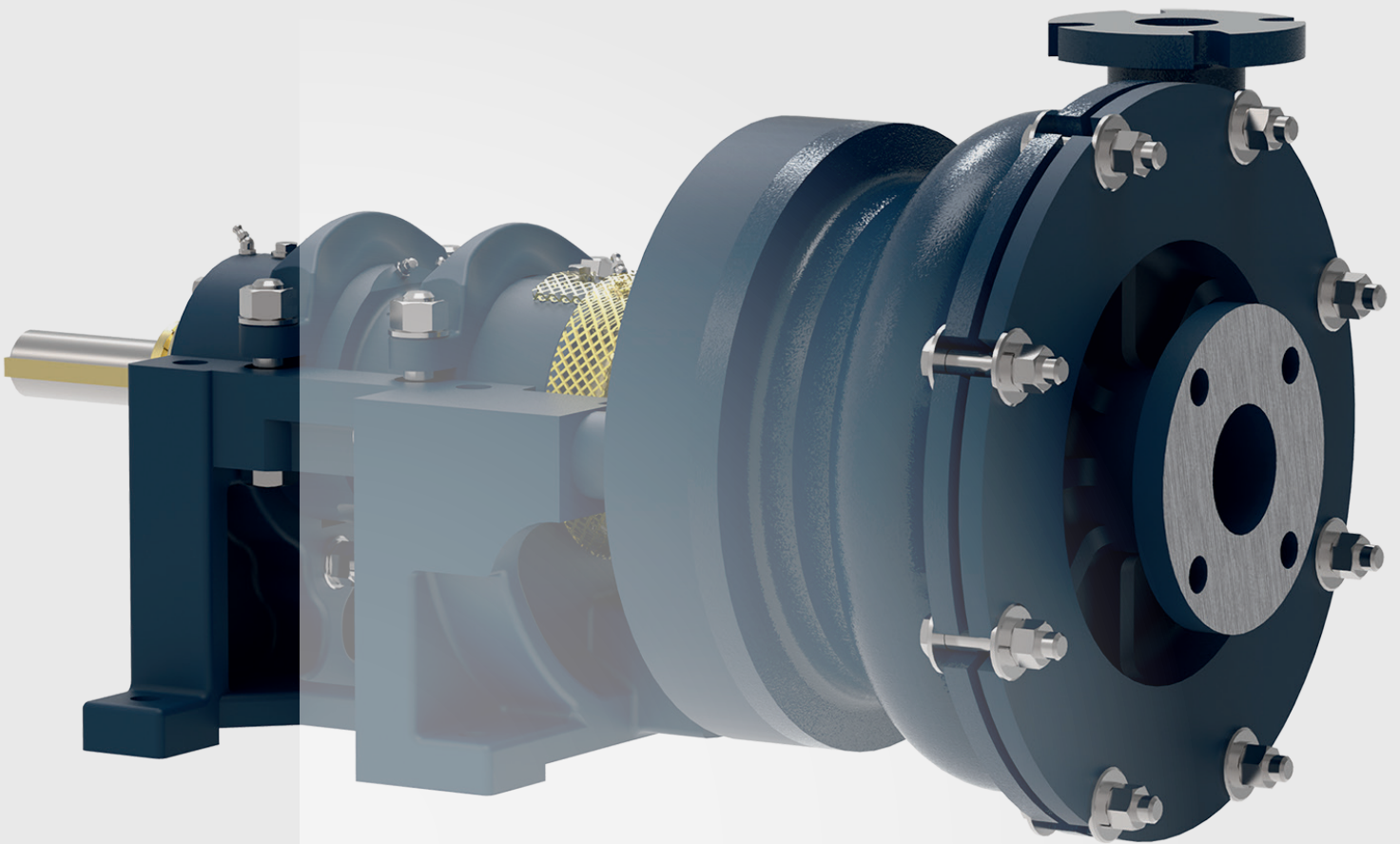

Don't let degradation and air locking plague your pump

Shearing and degradation can wreak havoc on your product quality. Air locking and pump wear lead to unplanned shutdowns and high maintenance costs. The KREBS® hMAX pump addresses all of these challenges and more, making it ideal for froth and shear-sensitive applications.

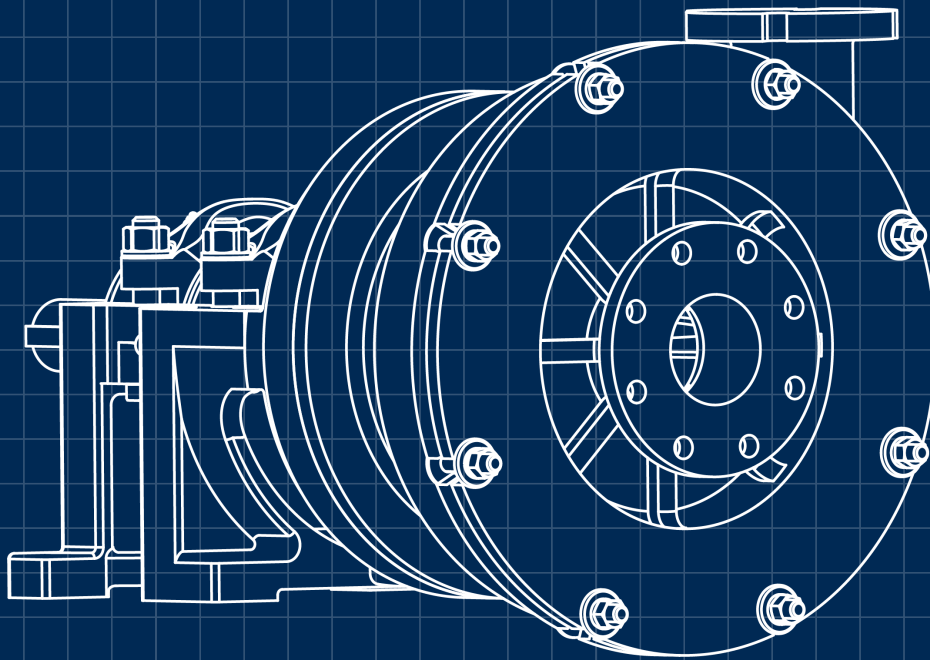

Key benefits

■
Minimised product degradation and shearing

■
Easily handles slurries entrained with air or gas

■
Pumps large fibrous materials

■
Extended wear life

Maintain the integrity of your product with our hMAX pump

Our hMAX centrifugal slurry pump is suitable for all industries where tramp material, product degradation, and entrained air can affect pump performance. We designed the hMAX to provide clear passage of large solids, and to minimise shearing, degradation, air locking and wear.

Minimised product degradation and shearing

Our hMAX pump maintains the integrity of your product by delicately handling solids in suspension. The large internal clearances allow for the clear passage of solids without contacting the impeller—reducing the chance of product degradation and shearing. The hMAX reduces carbon attrition and shear stress, making it an ideal choice for the carbon transfer in gold leaching processes. Your product is in good hands as the hMAX provides the lowest possible degradation of pumped activated carbon.

Easily handles slurries entrained with air or gas

In applications such as flotation, concentrate slurries have a significant amount of entrained air known as froth. When pumping froth slurry, special considerations must be taken since it does not perform as normal slurry at the same pump speed. The difference is due to the air, which expands in the low-pressure zone at the eye of the impeller and inhibits the flow going through the pump. Traditionally, pumps are oversized to account for the volume of air at the eye of the impeller so that they still generate the required flow rate.

Oversizing, however, is not the only solution! With a recessed impeller design, the hMAX allows for the clear passage of air entrained slurries without influencing the duty flow and head. Through constant recirculation, the open vortex impeller design allows for froth advancement without air locking. In fact, the hMAX can handle slurries containing up to 30% entrained air.

Pumps large fibrous materials

The hMAX is designed to provide safe passage of large, shear sensitive solids without clogging and without degrading the product. Long, stringy, fibrous materials are no match for the hMAX pump's recessed impeller. Tramp material such as large chunks of wood, plastic or metal pass through the pump with ease.

Extended wear life

The heavy-duty concentric casing design eliminates radial loads, which greatly extends the life of the pump, the seals and the bearings. Even at low flows, the hMAX provides performance and wear life that cannot be reached by many centrifugal pumps.

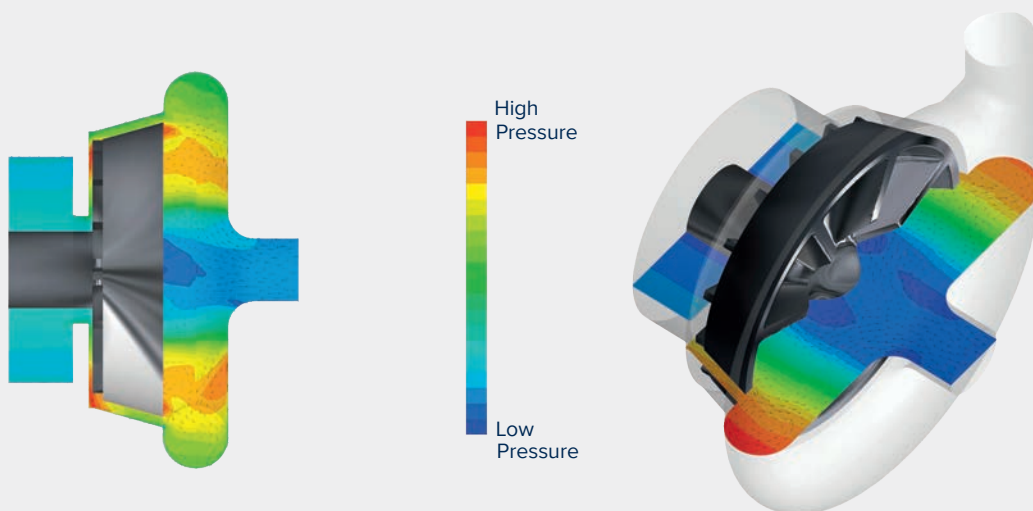

Recessed impeller creates a vortex that agitates slurry around the suction to keep solids in suspension

Unique features drive the hMAX pump's powerful performance

Recessed Impeller

- Provides large internal clearances that allow for the clear passage of large solids and reliable operation at low flows
- Minimizes solids degradation, shearing of slurry and wear rate
- Liquids containing entrained air or gas are more easily pumped

Casing

- Heavy-duty concentric casing design and recessed impeller reduce radial loads and extend bearing life
- Can pump almost anything that can pass through the discharge

Power frame

- Heavy-duty cast iron pedestal with external bearing assembly adjustment mechanism

Reverse-taper roller bearings

- Increase the effective load span to improve life
- Pumping action of taper rollers discharges grease to the outside, preventing ingress of slurry and eliminating possibility of failure due to over-greasing
- Heavy-duty shaft and taper roller bearings rated at 100,000 hours minimum of B10 life

Sealing options

- Water flush
- Centrifugal (expeller)
- Mechanical



Large internal clearance designed to provide safe passage of large, shear-sensitive solids without clogging and without degrading the product

Reverse-taper roller bearings

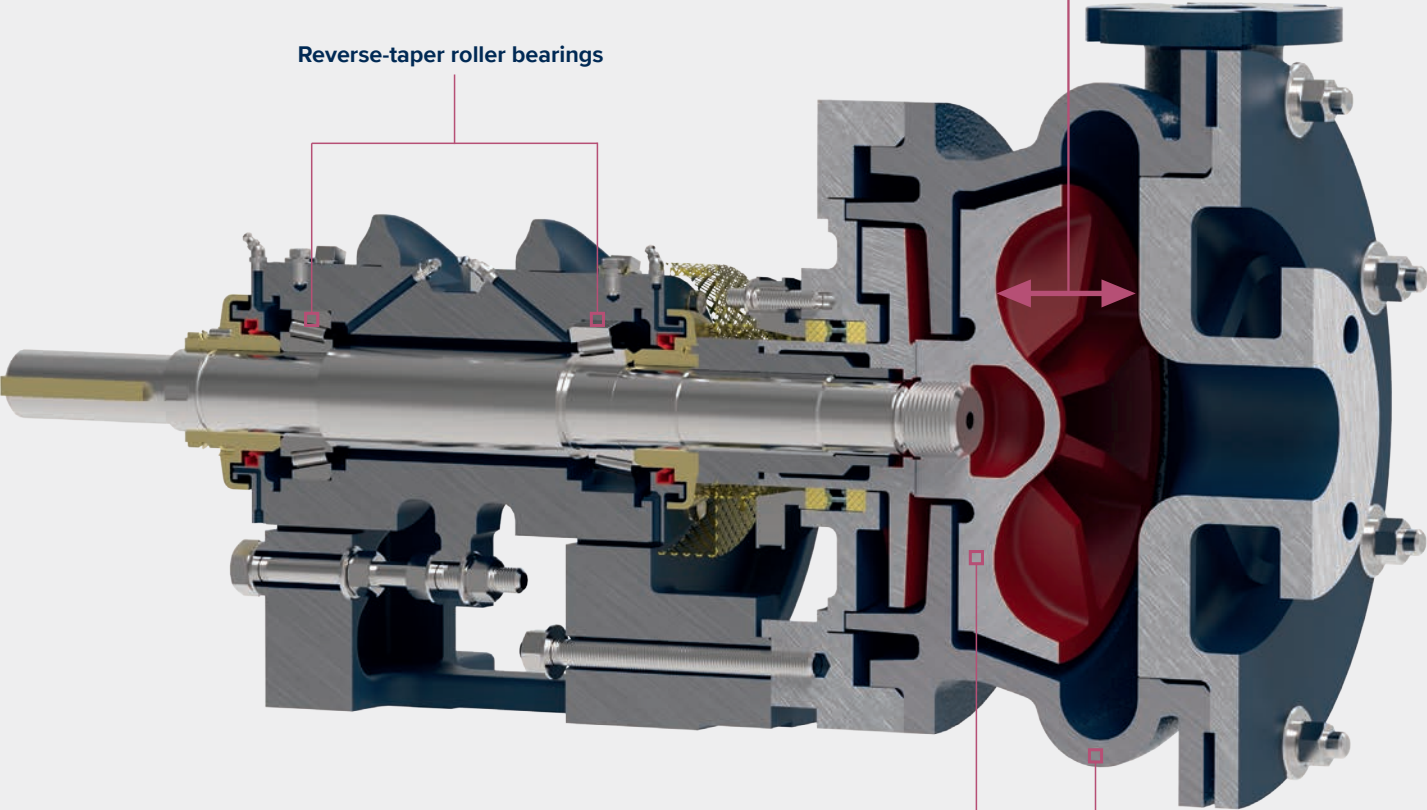

Recessed Impeller

Heavy-duty concentric casing

Applications across mining and industrial industries

KREBS pumps are designed using vast experience in pumping technology to meet challenges with throughput, downtime, wear life and overall efficiency. The complete slurry pumping solutions optimise performance, maximise wear life and efficiency and lower operating costs.

Mining applications:

- Activated Carbon Transfer (CIL/CIP/CIC & ADR)
- Froth
- All duties where degradation must be avoided

Industrial applications:

- Pumping paper pulp to cyclones feeding paper machines
- Grit pumping in the headworks of municipal wastewater plants
- Digester recirculation

World-class service and pump test facilities

Our performance test lab is further proof of our commitment to the advancement of the industry—through systems development, new product offerings, technical services and collaboration with outside entities.

Our ability to perform comprehensive testing on our products allows us to meet your needs and deliver a quality product and service solution. The testing we do also puts us at the forefront of the increasing technical demands of the industry as a whole.

hMAX pump size

(in)	(mm)
3 x 2	80 x 50
4 x 3	100 x 80
5 x 4	125 x 100
8 x 6	200 x 150
10 x 8	250 x 200



GLOBAL SALES LOCATIONS

FLSmidth - Australia

Pinkenba, QLD, Australia
Tel: +61 7 5519 5700
krebssaustralia@flsmidth.com

FLSmidth - Chile

Santiago, Chile
Tel: +56 2 2463 8350
krebsschile@flsmidth.com

FLSmidth - Philippines

Ortigas Center, Pasig City, Philippines
Tel: +63 2 687 9251
krebss-philippines@flsmidth.com

FLSmidth - Beijing

Beijing P.R. China
Tel: +86 10 8468 9100
krebsschina@flsmidth.com

FLSmidth - Brasil

Sao Paulo, Brasil
Tel: +55 15 3416 7400
krebssbrasil@flsmidth.com

FLSmidth - Austria

Neusiedl am See, Austria
Tel: +43 2167 3345
krebseurope@flsmidth.com

FLSmidth Private Limited

Chennai, India
Tel: +91 44 4748 1000
krebssindia@flsmidth.com

FLSmidth - South Africa

Johannesburg, South Africa
Tel: +27 0 10 210 4000
krebssafrika@flsmidth.com



Dependability and easy maintenance from the industry standard

Simply effective: Industrial DeGritting cyclones for municipal wastewater treatment plant.

✉ krebs@flsmidth.com



Reliable operation and proven knife gate design

Performance, service life, easy maintenance—all in one universal valve

🌐 www.flsmidth.com



Learn from our experts

Subscribe to our Discover Mining magazine on www.flsmidth.com

FLSmidth Inc.
Tucson Operations
5505 W. Gillette Road
Tucson, AZ 85743
USA

Tel: +1 520 744 8200
Fax: +1 520 744 8300
krebs@flsmidth.com

For more locations see global contact list on previous page or visit us at www.flsmidth.com

Copyright © 2019 FLSmidth A/S. ALL RIGHTS RESERVED. FLSmidth is a registered trademark of FLSmidth A/S. nextSTEP is a trademark of FLSmidth A/S. This brochure makes no offers, representations or warranties (express or implied), and information and data contained in this brochure are for general reference only and may change at any time.

Bringing better solutions to light

in the cement and mining industries

The future is full of possibilities and you are leading the way. But it's never a straight journey and it's easy to lose sight of true potential. With an ally by your side, who shares your ambitions and who sees your world from different angles, we will find the right way together.

For more than 135 years, we have challenged conventions and explored opportunities. Across more than 50 countries, we are 13,000 employees who combine our unique process-knowledge on projects, products and services to drive success. We develop the most advanced technology in our industries and offer market-leading product and service ranges.

Rooted in Danish values, we activate our knowledge and experience to navigate your complexity and bring better solutions to light. So no matter where in the world you are, we are here to help you discover new ground and achieve sustainable productivity enhancement.

We are the market-leading supplier of engineering, equipment and service solutions to customers in the global mining and cement industries.

We discover potential.

-  [flsmidth.com/linkedin](https://www.flsmidth.com/linkedin)
-  [flsmidth.com/twitter](https://www.flsmidth.com/twitter)
-  [flsmidth.com/facebook](https://www.flsmidth.com/facebook)
-  [flsmidth.com/instagram](https://www.flsmidth.com/instagram)
-  [flsmidth.com/youtube](https://www.flsmidth.com/youtube)

FLSmidth A/S
Vigerslev Allé 77
2500 Valby
Denmark

Tel. +45 36 18 10 00
Fax +45 36 30 18 20
info@flsmidth.com

www.flsmidth.com